

8 Non-Dual Singularity

José Díez Faixat
Independent researcher, Spain

Abstract

The Universe emerged in a violent Singularity – basically of energy – generating vertiginous transformations. Later, due to cooling, the emergence of novelties slowed down gradually. After the formation of the solar system and the subsequent emergence of life on our planet, the rhythm of creative transformations began to increase progressively, first through biological evolution and, later, through human development and expansion of civilizations. Currently, the emergence of novelties is again dizzying and everything seems to indicate that we are fast approaching another imminent Singularity – basically of consciousness – of infinite creativity.

In this paper we propose that both Singularities – A and Ω – are nothing but the polar expression of the fundamental Void always present, 'prior' to its apparent dualization as energy and consciousness. The initial and final Singularities would not be, in this way, but the points of exit from and entry to this eternally self-evident non-dual Emptiness that, instant after instant, manifests itself in and as the world of forms.

Keywords: *non-dual singularity, toroidal dynamics, divergent-convergent pattern, entropic-syntropic evolution, arrow of time, accelerated rhythm, final attractor, Big History.*

Introduction

During recent decades, the apparently solid view of the mechanistic and materialistic world has started to show alarming cracks. The approaches that a century ago were perceived as rigorous and almost irrefutable are starting to be seriously questioned. These approaches postulated that the Universe is moved by a simple game of chance, in progressive degradation and inexorably tending toward thermal death. In major contrast with these dark auguries, new science views – beset with surprise – a fascinating creativity in all spheres of reality. An unstoppable evolutionary current runs through entire history of the cosmos that generates all types of novelties. The supposed universal machine, virtually condemned to the scrapyard, is now revealed as a rare living being animated by a self-creative permanent force. It seems that Nature starts to reveal the secrets of its holistic inner tendency, which encourages it to climb the ladder of orga-

Evolution: Trajectories of Social Evolution 2022 214–256

nized complexity. This ascending drive has been creating progressively differentiated, integrated and inclusive units step by step.

Mechanistic science harbored the reductionist dream of explaining the functioning of complex structures starting out, exclusively, from its most basic components. New science has forsaken that dream on verifying repeatedly and in diverse levels of reality that the whole is greater than the sum of the parts. The flow of evolution engenders novelties which, though logically compatible with precedent structures, cannot however be explained by them. There is thus a dynamic, hierarchical schema of the world in which emerging levels are integrated with previous ones, thereby generating more complex, inclusive organisms with increasing awareness. Elementary particles are part of atoms, atoms are part of molecules, molecules are part of cells, cells are part of organisms and so on. The Universe thus reveals itself as a hierarchy that extends unlimitedly upward and downwards throughout the course of evolution.

On the other hand, each one of these levels of universal reality is structured by an infinite reciprocal interplay among individuals and communities. Some and many are involved like reflections in a grid of mirrors facing one another. An individual devoid of an environment is not possible, neither is a group without the individuals that compose it. One cannot distinguish isolated unities in these universal networks of interrelationships and interconnections. As Quantum Physics has demonstrated, the scope of these complex webs of relations goes beyond what is humanly conceivable, even transcending our time and space schemata. There are no actually separated 'parts' in any level of the evolutionary scale. On the contrary, as in a holographic plate, each 'fragment' of the world is no more than a concrete expression of the same, unique totality. The Universe starts to reveal itself to the eyes of new science as a unified field that is dynamically reflected in each and every corner of itself.

Attempts were made to build the world upon the solid and strong foundations of matter, but this myth has not stood up to empirical testing. Subatomic analysis has literally taken the floor away from under our feet. Our supposedly indestructible material basis has dissolved in pure forms, patterns, orders and relationships in a fabric that is no longer substantial, but purely abstract instead. We are supported by evanescent forms that vertiginously emerge and disappear in an intangible void. Within the scientific community, it has even been asserted that the Universe is beginning to look more like a great thought than a great machine.

The materialistic focus of classical science is also aimed at the 'objective' description of the world, putting the 'subject' making the description aside. However, the emergent postmodern perspective has once more revealed the complete naivety of this project. The observing mind is inevitably part of the observed universe. There is not object without subject, no outside without inside, no reality without consciousness. Both terms are definitively interrelated and therefore any attempt to comprehend the phenomenal world integrally must necessarily include both facets. The dynamics of evolution is thus perceived as

a generator of entities, not only progressively more organized and complex in their external appearance, but also, at the same time, of greater inner awareness. One cannot limit our vision solely to the surface of things, because, although we try to ignore them, the depths of lucidity will finally become patent to us over and over again.

The Universe that surprisingly begins to reveal itself before our gaze has little to do with that blind, insensitive artifact, that mechanical and inert world in which the human being imagining it, did not even have a place in it. The new approaches that study reality no longer consider us as aberrant creatures in a world without sense, but rather as radiant expressions of the creative flow of totality, authentic microcosms that reflect with increasing clarity, the infinite richness of a fascinating macrocosm.

Our research on the rhythm of evolution falls within this new perspective of a Universe that is self-creating – a generator of progressively more complex and organized novelties; hierarchical – in which each new level transcends and becomes integrated with all previous levels; holographic – in which each part reflects the totality; impermanent – in a continuous dance of creation and destruction; lucid – capable of knowing itself; and void – without a basic substance that supports it. In this new emerging outlook, our daring proposal that a harmonious pattern that governs the rhythm of evolution exists no longer sounds so shocking.

Beyond Darwin

Nowadays science agrees that evolution is a core feature of the Universe. There is a complete consensus regarding the dynamic and creative features of phenomenal reality in all fields of human knowledge – astrophysics, biology, psychology, sociology, and others. Nevertheless, there are discrepancies in the interpretation of the facts.

Darwin's theory of evolution was primarily based on random mutations and the 'survival of the fittest'. The 'synthetic theory' extended these formulations in the late 1930s and early 40s with the contributions of Mendelian genetics and population-based genetics, maintaining as explanatory basic elements the aforementioned random mutation and natural selection. This synthetic theory enjoyed almost unanimous acceptance for two or three decades, but gave rise to a great wave of dissent from 1970 on. The idea that the synthetic theory is wrong is beginning to take shape for many paleontologists, geneticists, embryologists and taxonomists, who refute the random factor as the sole principle governing the evolutionary process. They disagree that natural selection explains the emergence of new species. They affirm that fossil records do not fit Darwinian gradualism and denounce that the theory does not reflect the phenomenon of increasing complexity. Spontaneous mutations may explain variations within a certain species, but not the subsequent variations among them. Macroevolution or typogenesis – the evolution of these higher-order taxonomic categories –

show far too pronounced differences among divisions to have arisen from gradual transformations.

In recent years, the gradualist conception of evolution has been seen to be responsible for only a small part of evolutionary change. Furthermore, deepest changes in the biological evolution have been seen to take place in specific moments of the history of groups, occurring in a very rapid manner and giving rise to stable species that suffer very few subsequent variations. Fossil records mainly consist in thick layers of land in which some species are evenly distributed, separated by thin surfaces through which species suddenly change in a process of multiple speciation. Many paleontologists think that this intermittent history shown by fossils should not be attributed to simple gaps in the record, but that it basically demonstrates the rhythm with which life has evolved. Therefore, many of them have started to dispute the classical conception of the tempo of evolution. The Darwinian version of a slow, continuous and gradual process has given way to the interpretation characterized by discontinuous, sudden leaps and changes. There is hence an evident renaissance of the idea of vigorous, sudden and energetic speciation, versus calm gradation, strongly giving rise to the perception that fossil records contain much more information than what might be imagined via natural selection alone.

In 1972, N. Eldredge and S. J. Gould (1972) published a seminal paper in which they demonstrated that nature progresses by sudden leaps and profound transformations and not through small adaptations. According to the theory of punctuated equilibria, evolutionary leaps are relatively sudden processes; speciation stops for long periods in which existing species persist without fundamental variations and without creating new species (stasis). While a species persists, it remains relatively invariable; its legacy of genetic information is transmitted without major changes to the following generations. At some point, however, this stasis is suddenly broken and an evolutionary leap forward takes place. As Gould puts it, 'the history of any one part of the Earth, like the life of a soldier, consists of long periods of boredom and short periods of terror' (Gould and Eldredge 1977). Therefore, some researchers have begun to seek possible explanations for these sudden emergences of new species.

For some time, science is starting to understand that, simultaneous to the process of growth in homogeneity and positive entropy perceived in the Universe, the reverse phenomena occurs with the same naturalness, *i.e.* the progressive increase in heterogeneity and negative entropy. The latter is a mathematical counterpart of the concept of information which may be considered as a new measure for order and organization. Contrary to classic thermodynamics, which aimed to reduce the processes of self-organization to mere accidental events, to simple insignificant anecdotes, today's thermodynamics of disequilibrium allows us to understand the progressive and accelerated evolution of living beings and our own human history as something more than mere strange accidents in cosmic evolution.

Up until the 1970s, the researches tended to hold the conception that evolution acts mainly due to random factors. In the 1980s, however, many scientists started to be convinced that evolution is not an accident, but a necessary event that occurs when certain parametrical conditions are fulfilled. Laboratory experiments and quantitative formulations confirm the non-accidental character of the evolutionary processes. It is beginning to become evident that the continuous deployment of the organized complexity of the universe, its intrinsic sporadic capacity for sporadic self-organization constitutes a fundamental and profoundly mysterious property of reality. A new and fascinating paradigm is beginning to emerge that recognizes the surprisingly innovative and progressive nature of universal dynamics.

The new sciences of evolution thus perceive a new harmonious and natural coherence throughout the creative universal process from the mere originating instant. They deny that the random factor is the only explicative argument of novel phenomena and they claim that the old theory does not explain the surprising emergence of increasing complexity at all. On the contrary, they advocate the non-accidental character of evolutionary processes and provide numerous proofs that all dynamical systems, at different levels of reality, develop similar creative patterns. The new approaches show how any dynamic system far from a state of equilibrium may leave its permanent state when some of its environmental parameters change. In these situations, systems may spontaneously reach new states of equilibrium of greater complexity subsequent to a chaotic and indeterminate phase. The overall course of evolution thus looks like stairs in which horizontal steps alternate, almost without changes, with abrupt leaps in level.

Both within theoretical or empirical works, in hard or soft sciences, the aim is to understand the innate creative tendency of nature; the surprising patterns of organization in which the game of chance is channeled. We hear about: strange attractors (see Ruelle 1993), morphogenetic fields (see Sheldrake 1989), archetypal channels (see Waddington *et al.* 1976), implicate orders (see Bohm 1988), fractal structures (see Mandelbrot 1997) or stratified stabilities (see Bronowski 1970). It now seems evident that creativity cannot be reduced to a mere random product, but rather to the holistic intervention of unified fields that may explain both the overall totality of creative phenomena and their quality of instantaneity. The implacable integrity of these fields would also explain their capacity to organize diverse and independent elements in a harmonious way by means of a unique momentum. Our hypothesis about the rhythm of evolution gives this research new features and may also offer a line of work full of pleasant surprises.

A Harmonious Solution

The most fundamental statement of the Pythagoreans was that numbers constitute the unmovable principle of the world; the very essence of reality.

When they discovered that the proportions among musical harmonics could be expressed in a simple and exact form, they considered that the cosmos itself was a harmonious system of numerical ratios: all reality could be expressed by means of relationships among numbers. According to the Pythagoreans, the inherent numerical order of sounds was directly related with the very organization of the Universe. For them, music was therefore nothing other than the expression of the inner relationships of the cosmos. They even affirmed that all material manifestation was the result of the concert of universal vibrations.

At the beginning of the 20th century, physicists were confused on discovering that, far from presenting itself as predicted as a continuous flow, the energy emitted or absorbed by atoms presents itself in a quantifiable way, in very precise packages. For several decades, they tried to explain this strange phenomenon by seeking a sound new mathematical theory for the atom that would generate these quantum numbers in a natural way. The solution arrived with the proposition of the similarity between the world of electrons and that of musical harmonics – standing waves – thereby happily giving rise to the surprisingly precise wave equation by Schrödinger as the fundamental piece of revolutionary Quantum Physics. It thus seems that we are literally made of music, that we are pure abstract relationships in an unsubstantial reality, the acoustic appearance of the quantum void, the silent music and the sonorous solitude that amazed our mystics so much.

Standing waves are known by anyone that has played a musical instrument. The main feature of these waves is that they divide the vibrating element – string, tube or hoop – into completely equal sections. A guitar string, for example, cannot vibrate randomly due to the fact that it has fixed ends and therefore has to vibrate in such a way that its ends remain motionless. This is what limits its possible variations and introduces whole numbers. The string can undulate as a whole (see Fig. 1-A), in two parts (see Fig. 1-B), in three (see Fig. 1-C), in four, or in some other whole number of equal parts, but it cannot vibrate, for example, in three and a half parts or in five and a quarter.

In music theory, these successive standing waves are called ‘harmonic sounds’ or ‘harmonics’. The unlimited series of these harmonics, originating from the ‘fundamental sound’ of the complete original unity, define the varying degrees of the sonorous vibrations very precisely, *i.e.* the entire hierarchy of the levels of stability of the flow of music.

We thus see that both in the microscopic world of Quantum Physics and in the macroscopic reality of musical instruments, the ‘energies’ – vibrations – do not flow continuously, but in a quantified way according to a hierarchy of standing waves. At any level of reality, a vibrating element – atoms or guitar strings – intrinsically possesses very precise potential levels within which the flows of energy are stabilized.

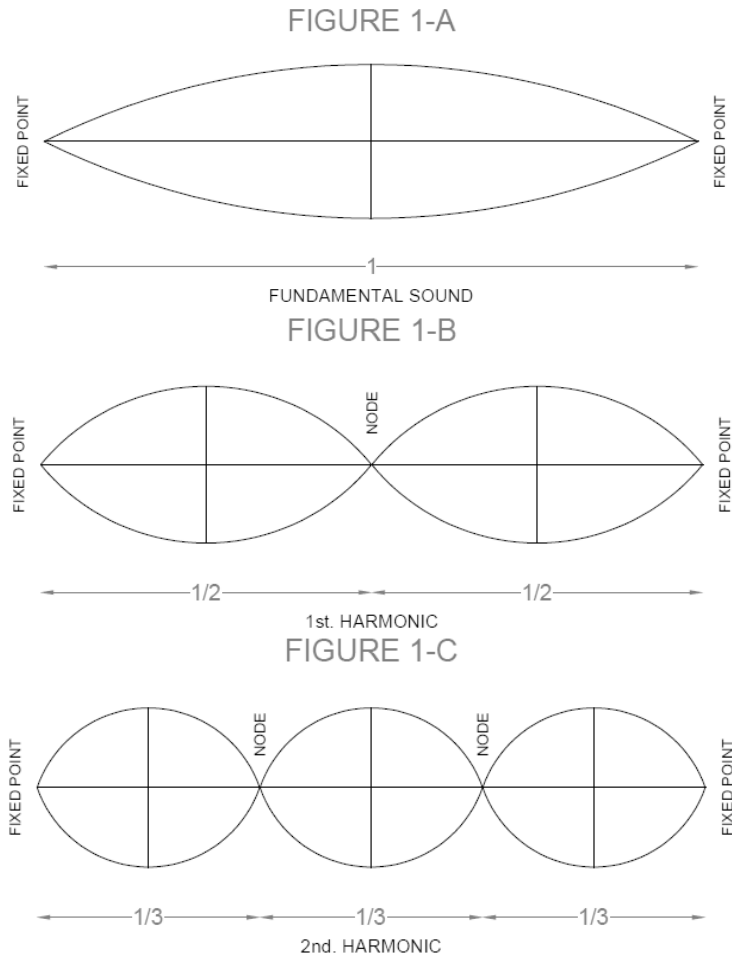

Fig. 1. Musical harmonics (standing waves)

We stated previously that the new science considers the Universe in a holistic way; in other words, that it perceives nature as an integrated wholeness, as a non-fragmented, undivided overall movement. We have also seen how the evolutionary dynamics of this unified universe displays its novelties in a discontinuous manner; just as the deepest transformations of evolution come about suddenly and abruptly. This generates a progressively more complex and more inclusive hierarchy of organization levels. We find, once again, a vibrating unity – the evolving universe – that channels its energy flow in a highly defined series of levels of stability. Like atoms. Like musical instruments.

Both in the world of atomic physics as in the world of music, the secret of their sudden leaps and discontinuities in sound was revealed thanks to standing waves and musical harmonics. Could not the same occur in the field of evolution? Does it not sound very coherent that this unified Universe that we are starting to discover generates similar creative patterns at its different levels of organization? Does it not therefore sound appealing that the sudden evolutionary changes in the history of the Universe respond precisely to these same standing waves that are the explanatory key of both the subatomic and musical world? This has been the basic intuition that has given rise to our hypothesis regarding the rhythm of evolution which we will now summarize below.

A Simple and Daring Hypothesis

Jacob Bronowski (1970) raised a theory regarding a unique process that explains hierarchically-ordered diversity without any recourse to reductionism. This theory suggests, as a general cosmologic principle, the concept of the 'stratified stability of potential levels' as the key to understanding the evolution of systems in disequilibrium. It basically suggests the existence of specific levels of stability around which energy streams gather and are organized, thereby permitting the subsequent and sudden upward leaps toward new layers or levels of progressively greater complexity. Our hypothesis constitutes a very precise specification in this appealing approach. Let us study it in greater detail.

Taking the example once again of the guitar string, let us imagine that it is tuned to C – the fundamental sound. If we make half of its length vibrate, the first harmonic, we will obtain the same original note in a higher octave. If we induce the vibration in a third of the string, the second harmonic, we will get a *different* note, which in this case will be G. This means that a tonal *novelty* emerges with the second harmonic. Taking the new note as a fundamental sound, we can likewise iterate the experience as many times as we wish and we will always obtain successive scaled sound novelties with each second harmonic. Thus, when we induce the vibration of a third of the length of the string, a *creative leap* will appear and with a third of the third, another one, and with a third of the third of the third, another new one, and so on.

This simple fact provides the key to our hypothesis. The proposal is very simple: considering the totality of time as a vibratory unity, the consecutive linked second harmonics, *i.e.* the successive thirds of the duration, will mark the emergence of evolutionary novelties. In other words, the second harmonics will define the 'potential levels of stratified stability' through which nature's creativity channels itself or the steps in the ladder of evolution through which the energy streams flow in their ascending process of creation of progressively more complex and conscious organisms. Figs 2-A, 2-B, 2-C show the overall process in graphic form. If we take the entire course of time – from the 'origin' to the 'end' – as the fundamental sound, we have sketched the consecutive leaps in level in both directions: in Fig. 2-B, the section from the origin to the second node 'P' of exteriorization, called the 'exit' or 'outwards' section; and in Fig. 2-A, the section from that same second node until the end – the 'return' or 'inwards' section. Fig. 2-C shows the joint trajectory, the overall ladder of evolution.

FIGURE 2-A

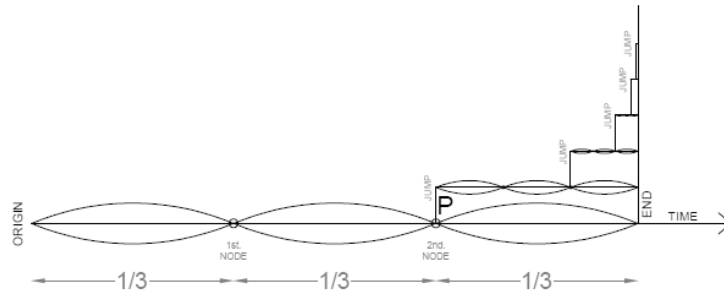

FIGURE 2-B

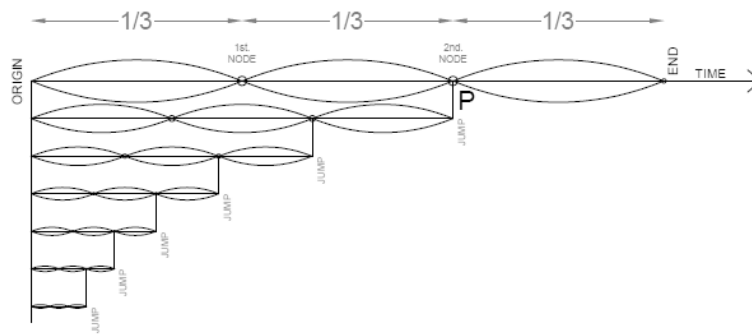

FIGURE 2-C

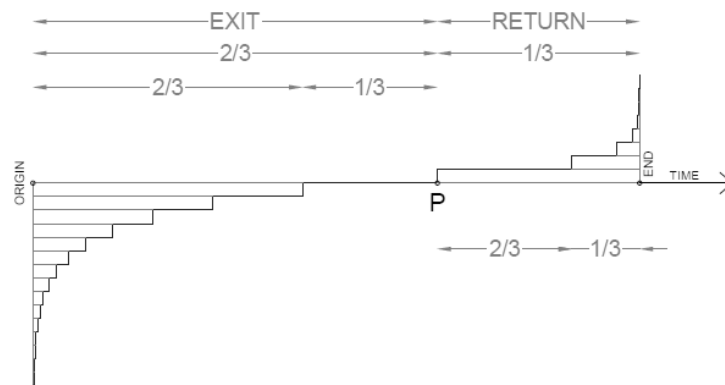

Fig. 2. Process of deployment of the successive levels of stratified stability from the original pole A to the final pole Ω . 'Exit' section (2-B). 'Return' section (2-A). Integral trajectory (2-C)

Summarizing our approach, we could say that, just like when a musical instrument emits a specific note, a wide range of its harmonics sound simultaneously, the Universe as a whole likewise has, from its first original vibratory instant, a complete potential hierarchy of standing waves through which its creative flows can ascend. According to our scheme, starting out from the precise vibration that gave rise to the origin to the Universe, the universal process commenced with a vertiginous explosion of creativity and leaps in level, gradually slowing down its rhythm on its ascending path toward a specific layer of the spectrum – ‘the fundamental sound’, and from there on starts to progressively accelerate the rhythm of its leaps in novelty along the ascending path towards a final moment of infinite creativity. Later on, we shall consider the profound meaning of these surprising poles: origin and end, Alpha and Omega, as it is precisely there where we will find the key to many of our questions.

Finally, in order to provide a coherent and ordered framework for our musical proposal of evolutionary rhythms, we will now present another observation. As stated earlier, if we tune a guitar string to C, its second harmonic, $1/3$ of its length, will be a G. Similarly, the second harmonic of this G will be a D. And that of this D will be an A. If we repeat the same operation indefinitely, over and over again, we will obtain a chain of sounds, C, G, D, A, E, B, F#, C#, G#..., that exactly reproduces the order of the successive notes of the Pythagorean ‘circle (spiral) of fifths’. If we consider each note in this chain to constitute the characteristic sound of a determined ‘cycle’, we will thus obtain, with each $1/3$ of the duration, a completely new sound and therefore a ‘leap in cycle’.

For scholars of the new evolutionary sciences, we would say that these second nodes of each cycle correspond to the moments of ‘chaos’ (see Gleick 1988), of ‘creative unbalances’ (see Prigogine and Stengers 1990), of ‘beneficial catastrophes’ (see Thom 1987), in which leaps in level or ‘bifurcations’ occur. At these points, the ‘attractors’ defining the previously expressed pattern disappear and those that define a new state subsequently appear ‘out of the blue’. Abruptly, the fundamental sound changes to its second harmonic.

After every seven cycles, the same series of notes is repeated in a higher semitone. We will use the term ‘series’ to refer to each one of the successive groups of seven cycles that keep on appearing – physical, biological, mental, intellectual, *etc.* and ‘series leap’ to refer to the transitions between them.

Our entire hypothesis of evolutionary rhythms can be reduced to what we have just presented. Just that. As simple as that: a ‘cyclic leap’ appears with each third of the duration, and after seven cyclic leaps a ‘series leap’ appears. It is truly amazing for such a simple scheme to provide such adjustment good fit to the all key steps of evolution, both in the global macrocosm – paleontological, anthropological and historical – as in the human microcosm – embryological and psychological. It is really striking that hardly anyone, except some daring researcher of the Big History, has noticed this clamorous and evident rhythm of events. One cannot see the woods for the trees.

Verification of the Hypothesis in Human Phylogeny and Ontogeny

Fitting our 'periodic table' of rhythms to the date of the appearance of matter – the Big Bang – and of organic life, we see that every single instant of the emergence of successive taxonomic degrees of human phylogeny is marked out with utter precision: *Kingdom: animal, Phylum: chordate, Class: mammal, Order: primate, Superfamily: hominoid, Family: hominid and Genus: homo!* The same then occurs with all the stages of maturation of our primitive ancestors: *H. habilis, H. erectus, archaic H. sapiens, H. sapiens and H. sapiens sapiens!* Once more, the precision of our hypothesis is repeated in the successive transformations that humanity has experienced in its more recent history: the *Neolithic, Antiquity, the Middle Ages, the Modern Age* and the emergent *Post-modern Age!* If, as we see it, all these stages resoundingly fit the provisions of the 'periodic table' of rhythms that we have proposed, it is more than likely that our hypothesis may also provide the key to glimpse the successive phases yet to be deployed in the years to come in an ever-accelerating process that will eventually lead to a moment of infinite creativity, Omega, within a couple of centuries, around the year 2217.

All this is, indeed, unexpected and surprising, but is even more shocking when we verify that the same hypothesis that has behaved with great precision when applied to the process of global evolution, also does so when cross-checked against the process of development of the individual human being. Within the same timeframe, with the same pattern of folding and unfolding, and passing through the same stages, our 'periodic table' of rhythms periodically marks out – step by step – the successive phases of which embryologists, developmental psychologists and spiritual teachers speak, thus confirming the old idea of phylogenetic-ontogenetic parallelism and pointing very specifically to an astonishing fractal and holographic universe (see Gould 2010).

We attune, then, with that classical idea, present in very different cultures, that the human organism encapsulates everything. It constitutes an individual concentration of the world, a unity that reflects, as in a mirror, the totality of the Universe. According to this approach, human development is a rapid recapitulation and integration of all the levels gradually deployed within the evolutionary process of the Universe throughout its slow, drawn-out paleontological development. But, moreover, our research reveals that not only is the entire evolutionary trajectory of our ancestors recapitulated, but it is also made according to an identical global pattern!

Due to space limitations, one cannot include the details of these verifications we are talking about here. Therefore, we invite readers interested in this research to consult our article 'Beyond Darwin: The Hidden Rhythm of Evolution' (Díez Faixat 2011).

According to our hypothesis, therefore, both the phylogenetic, historical or macrocosmic process, as well as the ontogenetic, individual or microcosmic process, are both expression, global or punctual, of the same and unique rhyth-

mic archetype, which defines the exit and return dynamics in the temporal manifestation of the Universe, so that both individuals and societies are limited to progressively actualize the successive levels of potential stability of the same original matrix.

Previously, we have outlined our global hypothesis in Fig. 2-C, in which we represent the complete time trajectory from the ‘origin’ pole to the ‘final’ pole, covering both the ‘exit’ or ‘outward’ section – from the initial point A to the second node P – as the ‘return’ or ‘inward’ section from that second node P to the final point Ω .

In Figs 3-A and 3-B we now represent, respectively, the global trajectories of human phylogeny and ontogeny, as is clear from the data provided by paleontology, anthropology and history in one case, and by embryology and the psychology of development in the other. Comparing the two graphs, it is obvious that the global patterns of both are identical in their structure and in the nature of each and every one of the stages traveled, and that the only difference between them lies in the level at which the pole P towards which the ‘exit’ section is oriented in each case: in the macrocosm it is situated in the ‘series leap’ between ‘matter’ and ‘life’ – the appearance of organic macromolecules after formation of the Earth –, and in the microcosm in the ‘series leap’ between the ‘mind’ and the ‘soul’ – the formation of the mature ego.

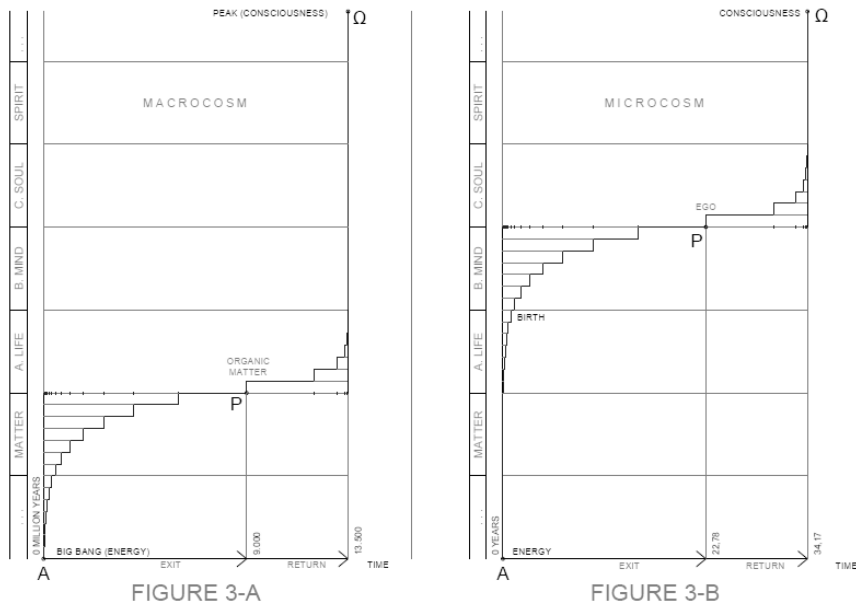

Fig. 3. Global trajectories of human phylogeny and ontogeny, from A to Ω : Macrocosm (3-A), Microcosm (3-B)

Comparing then, Fig. 2-C – our harmonic hypothesis – with Figs 3-A and 3-B tracked from the empirical data, the complete similarity between all of them is obvious. How is such an accumulation of coincidences possible?

The Non-Dual Foundation

Having tested our hypothesis with the data provided by the researchers of evolution and development, and after checking its surprising accuracy in all areas, it seems clear that it is no longer possible to attribute to the mere ‘chance’ all that multitude of chained coincidences that have been revealed.

From the materialistic paradigm, all of this seems inconceivable. It does not coincide at all with many of the core dogmas of official science. However, the facts are there and it is not possible to ignore the evidence. From this platform we invite all readers to try to find some explanation to this whole plot of unexpected events. For our part, we will outline below, telegraphically, a ‘philosophical’ proposal that can unveil the ultimate meaning of all we have discussed so far and, therefore, clarify the true nature of the Singularity towards which we are heading.

All manifested reality appears, inextricably, in the form of dualities. No form of expression is possible outside this play of the opposites. One cannot find sound without silence, object without subject, outside without inside, and so on. All opposites are mutually dependent and therefore we can understand them as polar manifestations of a reality that transcends them and that is ‘prior’ to this duality itself.

In the various graphs that we have used, for example in Figs 3-A and 3-B, one can see how the course of evolution starts at a pole of maximum energy (and practically no consciousness at all) and ends at another pole of maximum consciousness (and practically null energy). Physicists talk about an infinite potential energy in the original quantum void, while sages talk about a clear infinite consciousness in the final mystical void. We propose that these two voids are the same and unique Void, perceived by physicists objectively and by contemplative people subjectively, which in itself, is neither objective nor subjective, but ‘prior’ to that dual perspective. And the most fascinating thing of all is that this Void is not a distant metaphysical reality, but the simple and pure Self-Evidence of each and every present moment.

As there is no separation between subject and object in this Self-Evidence, it is not possible to see it, because there is not ‘anything’ that could be seen by ‘someone’, but neither is it ‘nothing’, because in fact all things in the Universe –

both objective and subjective – are mere partial and relative forms of this Self-Evidence. And although it is, therefore, unutterable, unexplainable, we may point to It, talking about an empty and self-luminous plenitude.

In order to be able to ‘see’ Self-Evidence, it needs to polarize Itself, at least apparently in subject and object, the same as 0 may become dual in +1 and –1 without changing, other than formally, its absolute value. We say this because our ultimate proposal is that, in order for Self-Evidence to contemplate Itself, it apparently splits in two poles: the original (basically, energy) and the final (basically, consciousness), generating an illusory distance among them which, on vibrating like the guitar string in our hypothesis gives rise to a whole scale of harmonics, which are precisely the levels of stability that create the evolutionary cycles that we have discussed here which span the entire range, from the most basic – of enormous energy and little consciousness – to the highest, of little energy and enormous consciousness, that harmoniously channel the so-called game of chance.

(Note the parallelism between the hypothesis we are proposing here and ‘superstring theory’, although the scope of application in our case is not simply reduced to the world of microphysics, but embraces the entire spectrum of reality).

If we see the things from this perspective, the entire avalanche of ‘coincidences’ that we have revealed here, which are totally unacceptable for the materialistic worldview, are shown to be natural manifestations of That-Which-Is. Or the teleological character of evolution, so denigrated by official science, is understood here as the logical expression of the fundamental structure of what is Real. Or the progressive emergence of consciousness, which is often completely forgotten in many branches of sciences, is presented in our non-dualistic approach as a simple appearance of the infinite lucidity of the ever-present Self-Evidence. Is it not time already to change the paradigm?

Coincident External and Internal Researches

When, back in 1981, I began to elaborate the present evolutionary hypothesis, it was really devastating to see the complete solitude in which I found myself. I had the feeling of having discovered something truly valuable, and, nevertheless, I did not find interlocutors with whom to share the findings and contrast opinions. These were difficult times of loneliness and incomprehension, which only began to clear up when Ervin Laszlo published my article ‘A Hypothesis on the Rhythm of Becoming’ (Díez Faixat 1993), in which I summarized my proposal, later expanded into book form (*Idem* 1996).

The panorama has completely changed recently when, through the Internet, I have begun to discover many other researchers who pose similar ideas. It has been a wonderful surprise and an immense joy for me to find the works of numerous authors who, independently and from very diverse perspectives, investigate the clamorous phenomenon of evolutionary acceleration and make proposals very similar to those that I have defended since many years. Special mention for the Russian astrophysicist Alexander D. Panov (2005), the American software engineer David J. LePoire (2012, 2015a, 2015b), the French paleontologist Jean Chaline (Chaline *et al.* 1999), the American computer scientist Carter V. Smith (2008), the Hungarian systems theorist Ervin Laszlo (1988), the French geologist André de Cayeux (1995), the Greek physicist and futurist Theodore Modis (2001), the American electrical engineer Richard L. Coren (2001), the American engineer, inventor and futurist Ray Kurzweil (2012), the Swedish software engineer Nick Hoggard (2020), the Spanish biologist Miguel García Casas (2007), the Australian systems theorist Graeme D. Snooks (1996), the Russian historian and sociologist Andrey Korotayev (2018), the Russian social psychologist Akop Nazaretyan (2014, 2015).

To highlight the obvious coincidences between the researches of these authors, in Fig. 4 I have elaborated a chart in which I outline the lists of the great evolutionary milestones proposed by several of them, including also the date that they suggest for the instant of Singularity towards which the Big History is directed. It is really fantastic to see how the graphs – whether linear or logarithmic – that reflect these listings are practically identical in all cases. There is only a very small difference, of one or two centuries, on the date of the final pole towards which the trajectories are oriented, but what are a hundred or two hundred years after a journey of more than 13,500 million years?

		J.D. FAIXAT	A. PANOV	C. SMITH	J. CHALINE	A. DE CAYEUX	
A	...	BIG BANG	(BIG BANG) MATTER	
		ORGANIC MOLECULE		ORGANIC MOLECULE			
A-1	1st NODE	PROKARYOTES (KINGDOM: ANIMAL)	PROKARYOTES	CELLS (VERTEBRATES)	PROKARYOTES		
	2nd NODE	EUKARYOTES	EUKARYOTES		EUKARYOTES		
A-2	1st NODE	MULTICELLULAR LIFE PHYLUM: CHORDATE	(CAMBRIAN EXPLOSION) VERTEBRATES		MULTICELLULARITY		
	2nd NODE	VERTEBRATE FISH			EXO-SKELETONS		
A-3	1st NODE	REPTILES (CLASS: MAMMAL)	REVOLUTION OF REPTILES	ANIMALS (PROSIMIANS)	TETRAPODS		
	2nd NODE	PRIMITIVE MAMMAL			HOMEOTHERMY		
A-4	1st NODE	P. PLACENTALS (ORDER: PRIMATE)	REVOLUTION OF MAMMALS		VIVIPARITY		
	2nd NODE	PROSIMIAN			PROSIMIANS		
A-5	1st NODE	MONKEY (SUPERFAM: HOMINOID)	REVOLUTION OF HOMINOIDS	MAMMALS	SIMIANS		
	2nd NODE	GREAT APES			GREAT APES		
A-6	1st NODE	HOMINIDAE (FAMILY: HOMINID)	REVOLUTION HOMINIDS		COMMON ANCESTOR PIGH		
	2nd NODE	HOMININI					
A-7	1st NODE	AUSTRALOPITHECUS (GENUS: HOMO)	PALEOLITHIC REVOL. HOMO HABILIS	AUSTRALOPITHECUS	AUSTRALOPITHECUS		
	2nd NODE	HOMO HABILIS		HOMINIDS	FIRST HOMO		
B-1	1st NODE	(I.L. MODE 1)	HOMO ERECTUS		HOMO SAPIENS	INITIAL LITHIC CULTURE	
	2nd NODE	HOMO ERECTUS				CHELLEAN ACHEULEAN	
B-2	1st NODE	(I.L. MODE 2)	ARCHAIC H. SAPIENS	(H. ERECTUS)			
	2nd NODE	ARCHAIC H. SAPIENS		ARCHAIC MAN			LEVALLOISIAN MOUSTERIAN
B-3	1st NODE	(I.L. MODE 3)	HOMO SAPIENS (REV. OF NEANDERTHALS)				
	2nd NODE	HOMO SAPIENS (NEANDERTHAL)					
B-4	1st NODE	(I.L. MODE 4)	H. SAPIENS SAPIENS (REV. OF CROMAGNON)	(H. SAPIENS SAPIENS)			
	2nd NODE	H. SAPIENS SAPIENS (CROMAGNON)		MAGIC			MESOLITHIC POLISHED STONE
B-5	1st NODE	(I.L. MODE 5)	NEOLITHIC REV.				
	2nd NODE	MESOLITHIC NEOLITHIC					
B-6	1st NODE	CIVILIZATION (ANCIENT TIME)	REVOLUTION OF CITIES	(ANCIENT AGE)		METAL AGES	
	2nd NODE	AXIAL AGE	REV. OF AXIAL ERA				
B-7	1st NODE	PATRISTICISM (MIDDLE AGES)	MIDDLE AGES	MYTHICAL			
	2nd NODE	SCHOLASTICISM					
C-1	1st NODE	EMPIRICISM (MODERN AGE)	1 ST INDUSTRIAL REV.	(MODERN AGE)		RENAISSANCE MACHINISM	
	2nd NODE	POSITIVISM	2 ND INDUSTRIAL REV.				
C-2	1st NODE	ECOLOGY (POSTMODERN AGE)	COMPUTER SCIENCE REVOLUTION	RATIONAL		ATOMIC AGE	
	2nd NODE						
C-3	1st NODE			INTEGRAL			
	2nd NODE						
...	
Ω		YEAR 2217	YEAR 2027	YEAR 2150	YEAR 2050 / 2110	YEAR 2100	

E. LASZLO	T. MODIS	R. COREN	R. KURZWEIL	N. HOGGARD	D. LEPOIRE
...	BIG BANG ... SOLAR SYSTEM	BIG BANG	BIG BANG ...	BIG BANG GRAVITATIONAL ... PLANET / LIFE
	FIRST LIFE	PROKARYOTIC LIFE	LIFE EUKARYOTES	SELF REPRODUCING FORMS OF LIFE	COMPLEX CELLS
	FIRST MULTICELLULAR LIFE CAMBRIAN EXPLOSION	EUKARYOTIC RADIATION	CAMBRIAN EXPLOSION	SEXUAL REPRODUCTION	CAMBRIAN
	FIRST MAMMALS	APPEARANCE OF CLASS MAMMALIA	REPTILES CLASS MAMMALIA	MAMMALS	MAMMALS
	FIRST PRIMATES		ORDER PRIMATE	PRIMATES	PRIMATES
	FIRST ORANGUTAN	APPEARANCE OF SUPERFAMILY HOMINOIDEA	SUPERFAMILY HOMINOIDEA	GREAT APES	
	FIRST HOMINIDS	APPEARANCE OF FAMILY HOMINIDAE	FAMILY HOMINIDAE		HOMINIDS
	FIRST STONE TOOLS	APPEARANCE OF GENUS HOMO	BIPEDAL ANCESTOR GENUS HOMO	HOMO HABILIS	HUMANS
	DEVELOPMENT OF SPEECH		SPOKEN LANGUAGE		SPEECH
	DISCOVERY OF FIRE	APPEARANCE OF ARCHAIC HOMO SAPIENS		ARCHAIC HOMO SAPIENS	FIRE
	EMERGENCE OF "MODERN HUMANS"		HOMO SAPIENS		ECO ADAPTATION
NOMADIC HUNTER-GATHERER SOCIETY	ROCK ART	APPEARANCE OF H. SAPIENS SAPIENS	H. SAPIENS SAPIENS	HOMO SAPIENS SAPIENS	MODERN HUMANS
AGROPASTORAL SOCIETY SETTLEMENTS	AGRICULTURE	DEVELOPMENT OF COMMUNAL VILLAGES	ART AGRICULTURE		AGRICULTURE
AGRICULTURAL SOCIETY	WRITING DEMOCRACY	DEVELOPMENT OF WRITING	WRITING CITY-STATES	FIRST CIVILIZATION	CIVILIZATION
PRE-INDUSTRIAL FEUDAL SOCIETY	CHRISTIANITY GUNPOWDER				COMMERCIAL REVOLUTION
INDUSTRIAL SOCIETY	RENAISSANCE INDUSTRIAL REVOL.	DEVELOPMENT OF PRINTING	PRINTING INDUSTRIAL REVOL.	FIRST TECHNOLOGICAL REVOLUTION INDUSTRIAL REVOL.	SCIENCE / EXPLORATION INDUSTRIAL
POST-INDUSTRIAL SOCIETY	MODERN PHYSICS DNA INTERNET	DEVELOPMENT OF DIGITAL ELECTRONICS	ELECTRICITY COMPUTER PERSONAL COMPUTER	INVENTION OF COMPUTER WWW	INFORMATION
...
	YEAR 1990	YEAR 2140	YEAR 2045	YEAR 2004	FIRST YEARS OF THE 21ST CENTURY

Fig. 4. The main evolutionary and historical thresholds according to various researchers (e.g., J. D. Faixat, A. Panov, C. Smith, J. Chaline, A. de Cayeux, E. Laszlo, R. Coren, R. Kurzweil, N. Hoggard and D. LePoire)

Almost all these researchers that I have just mentioned raise their evolutionary ladders from data obtained in the 'objective' or 'external' world. It is truly fascinating to see how researchers of the 'subjective' or 'internal' dynamics – development psychologists – propose a similar and complementary ladder, in which they define a series of very specific stages that, given the suitable circumstances, human beings and societies cross sequentially with universal character.

To show this surprising coincidence between our external evolutionary cycles and the inner stages posed by developmental psychologists, in Fig. 5 I have prepared another table in which I outline the successive stages proposed by each one of them in the different specific areas in which they carry out their research: Jean Piaget (see Piaget and Inhelder 1969), Michael L. Commons and Francis A. Richards (cognitive) (1984), Jean Gebser (2011) and Ken Wilber (worldviews) (see Wilber 2007), Abraham Maslow (needs) (see Maslow 1972), Clare W. Graves (see Graves 2005) and Jenny Wade (values) (see Wade 1996), Don E. Beck and Chris Cowan (Spiral Dynamics) (see Beck and Cowan 2006), Jane Loevinger (1976) and Susanne Cook-Greuter (identity of the self) (see Cook-Greuter 1985), Lawrence Kohlberg (moral) (see Kohlberg 1981), James Fowler (stages of faith) (see Fowler 1981) and Robert Kegan (orders of conscience) (see Kegan 1994).

Everything seems to indicate that the ladder of evolution and development set out independently by the researchers of the inner and outer worlds is one and the same, although approached, logically, from two different perspectives. To visualize this surprising identity between both approaches, let us graphically represent (see Fig. 6) the accelerated emergence of the joint process, taking as a script the transdisciplinary (bio-psycho-socio-cultural) model of Spiral Dynamics.

Spiral Dynamics is rooted in the long-standing and thorough research of professor of psychology Clare W. Graves into the evolution of individuals and societies. Analyzing the different ways of thinking and ways of being of human beings, he identified a number of common patterns or basic value systems and integrated them into a multilayered model of progressively complex levels. Graves held that the nature of human beings is an open system in constant evolution which advances by quantum leaps from a stationary state to another through a hierarchy of ordered, relatively stable systems, which unfurl spirally over the entire historical process of humankind from its beginnings to the present. He posited that these emergent stages are not rigid steps, but rather flowing, overlapping and interrelated waves, leading to the expansive spiral dynamics of individual and collective development, driven by their own internal dynamics and changing conditions of life. As it possesses a broader perspective and a more complex capacity for organization, each emergent wave 'transcends and includes' – as Wilber puts it – all previous waves, acquires the maximum importance for a period of time and ultimately ends up being 'transcended by and included in' a new, broader-ranging and more complex wave.

After Graves' death, his co-workers Don E. Beck and Chris Cowan continued to develop and corroborate their mentor's theoretical model and used it as the basis for their book *Spiral Dynamics: Mastering Values, Leadership, and Change*. These authors call the successive paradigms that define each of the eight basic levels of the spectrum 'value memes' or 'vMemes'. As can be seen from Fig. 5, the eight levels of Spiral Dynamics exactly coincide, one by one, with all the cycles of our hypothesis between B-4 and C-4. It occurred to Beck and Cowan to identify each of these levels with a certain color, thus facilitating the understanding and dissemination of their intelligent and effective model. The basic characteristics of these levels or colors are as follows:

Beige: Survival Sense. Impulsiveness. Biological automatism [Nomadic hordes. 'Savagery'.]

Purple: Kin Spirit. Magic-animist thinking. Taboos. Rituals [Tribal settlements. 'Barbarism'.]

Red: Power Gods. Myths of heroes. Conquest. Tyranny. [Ancient empires. 'Enslavement'.]

Blue: Truth Force. Absolutist thinking. Divine code. Obedience. Guilt. [Medieval kingdoms. 'Feudalism'.]

Orange: Strive Drive. Empiricism. Competition. Growth. Success. Material goods. Individualism. [National states. 'Capitalism'.]

Green: Human Bond. Solidarity. Relativism. Pluralism. Sensitive self. Equality. Human rights. Feminism. Ecology.

Yellow: Flex Flow. Process integration. Systemic thinking. Complexity. Interdependence. Open systems. Spontaneity.

Turquoise: Global View. Fractal reality. Spiral dynamics. Universal harmony. Holographic connections. Transpersonal mentality. Cosmic spirituality.

Fig. 6 shows the successive vMemes (colors), both individually and collectively, illustrating the historical periods in which each began to emerge (increasing gradation of color), the stages during which they dominated the collective panorama (continuous color) and the phases during which their predominance waned (decreasing gradation of color). The conclusions to be drawn from the graph are evident. On the one hand, we have said that spiral dynamics is expansive and therefore with each twist – transcending and integrating all previous stages – its level of consciousness and ability to embrace greater complexity increases. On the other hand, we have found that the duration of the successive stages decreases, one after another, at a dizzying rate, and that within a couple of centuries a moment of infinite creativity will thus be reached. At that moment, in that Singularity, consciousness will have transcended and included the entire spectrum of reality, and the ever-present truth in the timeless Emptiness – the non-duality of energy and consciousness, of object and subject, of origin and end – will become manifest in the world of forms.

Non-Dual Singularity

Alan Watts said that ‘the current will not start to flow from the positive end of a cable until the negative terminal has been established’ (see Watts 1972: 105). That is the idea. The universe of forms would not have arisen from the Void through the original Singularity A of the Big Bang if the final Singularity Ω had not been simultaneously present. This is possible because, as we have stated previously, A and Ω are but the polar appearance of the fundamental always present Emptiness – Self-evidence – and, therefore, the temporal distance that separates both Singularities is illusory. Everything happens Now.

According to our hypothesis, the key of the creative leaps deployed throughout evolution and history is in the standing waves that are generated, in the same original moment, from the fundamental sound. As we have seen, the cause of these standing waves is that the ends of the vibrating unit are fixed and, therefore, limit the possibilities of oscillation, thus generating the entire quantum spectrum of musical harmonics. One should remember that these harmonics are the potential archetypes that, one after another, are updated in and as the successive steps of evolution and history.

The key to the whole evolutionary process lies, then, in its original and final poles. The Universe would not have arisen without the simultaneous presence of the singularities A and Ω , exit from and entry to the full Emptiness. The final Singularity towards which we are directed is, then, nothing less than the antagonist of the original Singularity. From our point of view, it is a pole of the same caliber as the initial moment of the Big Bang. If this original pole consisted, basically, in an *explosion* in the realm of ‘energy’, the final pole towards which we are heading vertiginously will consist, fundamentally, of an *implosion* in the realm of ‘consciousness’. But, let us take a closer look, as we said before, both facets – the ‘energy’ and the ‘consciousness’ – are not two different realities, but polar aspects of the same and only Emptiness, the objective and subjective facets of the simple and full ever present Self-evidence. Hence, from our perspective, the ‘trick’ of evolution and history will be definitively revealed at this forthcoming final instant. That is, the entire trajectory from the Big Bang to today has occurred in this eternal Now that we in fact are. It will thus be made manifest that our life has not been a mere fleeting fragment in the midst of an endless process, but that we have, in fact, always been the pure, timeless Self-evidence in which all worlds have happened, happen and will happen. There has been no ‘before’. There will be no ‘after’. There is only Now. Is it not self-evident (see Díez Faixat 2007)?

Faced with this radical interpretation of the next Singularity, there are other authors who propose different alternatives. So, for example, Ray Kurzweil, one of the most prestigious researchers of technological acceleration, locates the moment of the Singularity in 2045. He states that the non-biological intelli-

gence created in that year will be a billion times more powerful than all human intelligence today. He interprets, then, the Singularity as a leap in leadership from the biological human to the artifacts of artificial intelligence. However, that does not seem to really be the true evolutionary summit, because, subsequently, in his book *The Singularity Is Near*, he states that our civilization will expand outward, turning all the dumb matter and energy that we comprise into highly intelligent (and transcendent) matter and energy (Kurzweil 2012: 445). So, in a sense, one can say that the Singularity will eventually imbibe the Universe with its spirit. Kurzweil specifies that we will manage to saturate the Universe with our intelligence before the end of the 22nd century and states, ‘Once we saturate the matter and energy of the universe with intelligence, it will “wake up”, be conscious, and sublimely intelligent. That’s about as close to God as I can imagine’ (*Ibid.*: 430). Accordingly, it thus seems that the real evolutionary summit will not take place in 2045, but it will occur in the late 22nd century, when all the energy and intelligence of the Universe will be experienced in a unified way.

Seen in this way, the coincidence with my proposal seems quite clear, in terms of both date and content. As we have posited in this paper, at the *beginning of the 23rd century* – around the year 2217 – *energy* and *consciousness* will reveal their ultimate non-duality. According to Ray Kurzweil, at the *end of 22nd century*, all the *energy* of the Universe will be saturated with *intelligence* and the Singularity will eventually imbibe this universe with its spirit. Does not that all sound very similar?

There are other researchers who propose the third interpretation of the Singularity. Thus, for example, Theodore Modis, David LePoire or Andrey Korotayev consider that the vertex of the evolutionary spiral towards which we are heading is not so much a summit of infinite creativity, but a simple turning point in the rhythm of emergence of novelties, around which the accelerated process of evolution reverses its direction and begins a gradual slowdown in the cadence of the transformations. This approach could also be compatible with the approach of the present paper: it would be enough to consider that only some individuals and collectives managed to implode in the fundamental Void, while the rest would initiate a long phase of slowing towards final stability.

Whichever is the most correct interpretation about the nature of the next Singularity, it seems evident that, in any case, all the researchers involved in this debate have discovered a very precise evolutionary pattern in the midst of the apparently random universal dynamics. It is obvious then, that taking into account the scope and profound implications of the finding, now open a host of new perspectives. Therefore, from here I invite all readers to research the suggestive paths that begin to glimpse. We may discover then, that reality is much more fascinating than we could ever have imagined.

References

- Arber A. 1954.** *The Mind and the Eye: A Study of the Biologist's Standpoint*. New York: Cambridge University.
- Arcidiacono G., and Arcidiacono S. 1991.** *Sintropia, Entropia, Informazione*. Roma: Di Renzo Editore.
- Arcidiacono S. 1992.** *L'evoluzione dopo Darwin. La teoria sintropica dell'evoluzione*. Roma: Di Renzo Editore.
- Bak P., Tang C., and Wiesenfeld K. 1987.** Self-organized Criticality: An Explanation of 1/F Noise. *Physical Review Letters* 59(4): 381–384.
- Beck D., and Cowan C. 2006.** *Spiral Dynamics*. Oxford: Blackwell Publishing.
- Bentov I. 2000.** *A Brief Tour of Higher Consciousness: A Cosmic Book on the Mechanics of Creation*. Inner Traditions – Bear & Co. Rochester.
- Bergson H. 1973.** *La evolución creadora*. [L'évolution créatrice]. Madrid: Ed. Espasa-Calpe.
- Bohm D. 1988.** *La totalidad y el orden implicado [Wholeness and the Implicate Order]*. Barcelona: Ed. Kairós SA.
- Brillouin L. 1959.** *La science et la théorie de l'information*. Paris: Masson.
- Bronowski J. 1970.** New Concepts in the Evolution of Complexity. Stratified Stability and Unbounded Plans. *Zygon* 5.
- Chaline J., Nottale L., and Grou P. 1999.** L'arbre de la vie a-t-il une structure fractale? *Académie des sciences*. Paris: Elsevier.
- Commons M. L., and Richards F. A. 1984.** A General Model of Stage Theory. *Beyond Formal Operations, Late Adolescent and Adult Cognitive Development* / Ed. by M. L. Commons, F. A. Richards, and C. Armon, pp. 141–157. New York: Praeger.
- Cook-Greuter S. 1985.** *Nine Levels of Increasing Embrace in Ego Development*. Wayland, MA: S. Cook-Greuter.
- Coren R. 2001.** Empirical Evidence for a Law of Information Growth. *Entropy* 3(4): 259–272. URL: <https://www.mdpi.com/1099-4300/3/4/259>.
- De Cayeux A. 1995.** ¿Qué curva sigue la humanidad? [Quelle courbe suit l'humanité?]. Barcelona: Revista 3er. milenio, nº 23.
- Costa de Beauregard O. 1994.** *Irreversibilità, entropia, informazione*. Roma: Di Renzo Editore.
- Cramer J. G. 1986.** *The Transactional Interpretation of Quantum Mechanics*. *Reviews of Modern Physics* 58: 647–688.
- Cramer J. G. 2016.** *The Quantum Handshake – Entanglement, Nonlocality, and Transactions*. Springer.
- Di Corpo U., and Vannini A. 2011.** The Evolution of Life. According to the Law of Syntropy. *Syntropy Journal*. URL: <http://www.sintropia.it/journal/english/2011-eng-1-2.pdf>.
- Di Corpo U., and Vannini A. 2012.** Syntropy, Cosmology and Life. *Syntropy Journal* 1. URL: <http://www.sintropia.it/journal/english/2012-eng-1-6.pdf>.
- Díez Faixat J. 1993.** A Hypothesis on the Rhythm of Becoming. *World Futures: The Journal of General Evolution* 36(1): 31–56.

- Díez Faixat J. 1996.** *Entre la evolución y la eternidad*. Barcelona: Ed. Kairós.
- Díez Faixat J. 2007.** *Siendo nada, soy todo*. Madrid: Ed. Dilema.
- Díez Faixat J. 2011.** *Beyond Darwin: The Hidden Rhythm of Evolution*. URL: http://byebyedarwin.blogspot.com/p/english-version_01.html.
- Driesch H. 1914.** *The History & Theory of Vitalism*, London: MacMillan and Co.
- Eddington A. S. 1928.** *The Nature of the Physical World*. Cambridge: Cambridge University Press.
- Einstein A. 1926.** *The Born-Einstein Letters*. New York: Walker and Company.
- Eldredge N., and Gould S. J. 1972.** Punctuated Equilibria: An Alternative to Phylogenetic Gradualism. *Models in Paleobiology* / Ed. by T. J. M. Schopf, pp. 82–115. San Francisco: Freeman, Cooper & Co.
- Elsässer W. 1958.** *The Physical Foundations of Biology*. New York: Pergamon Press.
- Fantappiè L. 1942.** Sull'interpretazione dei potenziali anticipati della meccanica ondulatoria e su un Principio di finalità che ne discende. *Rend. Acc. d'Italia* 7(4), fasc. 1–5.
- Fantappiè L. 1942.** *Principi di una teoria unitaria del mondo fisico e biologico*. Roma: Di Renzo Editore.
- Fantappiè L. 1993.** *Conferenze scelte*. Roma: Di Renzo Editore.
- Feigenbaum M. 1976.** *Universality in Complex Discrete Dynamics*. Los Alamos Theoretical Division Annual Report.
- Fowler J. 1981.** *Stages of Faith*. San Francisco: Harper & Row.
- Fuller R. B. 1981 [1982].** *Synergetics: Explorations in the Geometry of Thinking*. London: Macmillan Pub Co.
- Fuller R. B. 1982.** *Synergetics: Explorations in the Geometry of Thinking*. London: Macmillan Pub Co.
- García Casas M. 2007.** *Teoría de la vida embarazada y la reprobolución*. URL: www.upv.es/jugaryaprender/vidaembarazada/VER.pdf.
- Gebser J. 2011.** *Origen y presente [Ursprung und Gegenwart]*. Vilaür: Ed. Atalanta.
- Gould S. J., and Eldredge N. 1977.** Punctuated Equilibria: The Tempo and Mode of Evolution Reconsidered. *Paleobiology*: 3(2): 115–151.
- Gould S. J. 2010.** *Ontogenia y filogenia [Ontogeny and Phylogeny]*. Barcelona: Ed. Crítica.
- Graves C. 2005.** *The Never Ending Quest*. Santa Bárbara: ECLLET.
- Gribbin J. 1996.** *Schrödinger's Kittens and the Search for Reality*. Back Bay Books.
- Hameroff S., and Penrose R. 2014.** Consciousness in the Universe: A Review of the 'Orch OR' Theory. *Physics of Life Reviews* 11(1): 39–78.
- Haramain N., Brown W., and Val Baker A. 2016.** The Unified Spacememory Network: From Cosmogogenesis to Consciousness. *NeuroQuantology* 14(4): 657–671. URL: <https://holofractal.org/spacememory.pdf>.
- Hoggard N. 2020.** *A Feigenbaum Cascade of Generalized Darwinian Processes in Evolution*. URL: <https://vixra.org/abs/2006.0055>.
- Jung C. 1990.** *Sincronicidad. [Synchronicity]*. Málaga: Ed. Sirio.
- Kastner R. E. 2012.** *The Transactional Interpretation of Quantum Mechanics: The Reality of Possibility*. Cambridge: Cambridge University Press.

- Kastner R. E. 2015.** *Understanding Our Unseen Reality: Solving Quantum Riddles*. Imperial College Press.
- Kastner R. E. 2019.** *Adventures in Quantumland: Exploring Our Unseen Reality*. World Scientific Publishing Europe Ltd.
- Kegan R. 1994.** *In Over Our Heads*. Cambridge: Harvard University Press.
- Koestler A. 1982.** *The Ghost in the Machine*. Last Century Media.
- Kohlberg L. 1981.** *The Philosophy of Moral Development*. San Francisco: Harper & Row.
- Korotayev A. 2018.** *The 21st Century Singularity and Its Big History Implications: A Re-analysis*. URL: <https://jbh.journals.villanova.edu/article/view/2329>.
- Kurzweil R. 2012.** *La Singularidad está cerca [The Singularity is Near]*. Berlin: Lola Books.
- Laszlo E. 1988.** *Evolución: la gran síntesis [Evolution: The Grand Synthesis]*. Madrid: Ed. Espasa-Calpe.
- Laszlo E. 2013.** *El paradigma akáshico [The Akasha Paradigm]*. Barcelona: Ed. Kairós.
- LePoire D. J. 2012.** *An Exploration of Historical Transitions with Simple System Dynamics Models*. First International Big History Conference, Aug. 2–5. Grand Rapids, MI.
- LePoire D. J. 2015a.** Potential Nested Accelerating Returns Logistic Growth in Big History. *Evolution: From Big Bang to Nanorobots* / Ed. by L. Grinin, and A. Korotayev, pp. 46–60. Volgograd: ‘Uchitel’ Publishing House.
- LePoire D. J. 2015b.** Interpreting Big History as Complex Adaptive System Dynamics with Nested Logistic Transitions in Energy Flow and Organization. *Emergence: Complexity & Organization* 17(1): 1–5.
- Loevinger J. 1976.** *Ego Development: Conceptions and Theories*. San Francisco: Jossey-Bass.
- Lorenz E. 1963.** Deterministic Nonperiodic Flow. *Journal of the Atmospheric Sciences* 20(2): 130–141.
- Mandelbrot B. 1997.** *La geometría fractal de la naturaleza [The Fractal Geometry of Nature]*. Barcelona: Tusquets Editores.
- Maslow A. 1972.** *El hombre autorrealizado [Towards a Psychology of Being]*. Barcelona: Ed. Kairós.
- Meijer D., and Geesink H. 2017.** Consciousness in the Universe is Scale Invariant and Implies an Event Horizon of the Human Brain. *NeuroQuantology* 15(3): 41–79.
- Modis T. 2001.** *Forecasting the Growth of Complexity and Change*. URL: http://www.growth-dynamics.com/articles/Forecasting_Complexity.pdf.
- Nazaretyan A. 2015.** *Peering into the 21st Century: Mega-History and Its ‘Mysterious Singularity’*. URL: <http://temnyjles.narod.ru/Nzrtn/Xxi-angl.htm>.
- Nazaretyan A. 2014.** *Futuro no-lineal [Nonlinear Futures]*. Buenos Aires: Ed. Suma Qamaña.
- Panov A. 2005.** Scaling Law of the Biological Evolution and the Hypothesis of the Self-Consistent Galaxy Origin of Life. *Advances in Space Research* 36. URL: http://alpha.sinp.msu.ru/~panov/ASR_Panov_Life.pdf.
- Piaget J., and Inhelder B. 1969.** *The Psychology of the Child*. New York: Basic Books.
- Polanyi M. 1967.** Life Transcending Physics and Chemistry. *Chemical and Engineering News* 45.

- Pribram K. 1971.** *Languages of the Brain*. Brandon House.
- Prigogine I., and Stengers I. 1990.** *La nueva alianza [La nouvelle alliance]*. Madrid: Alianza Ed.
- Ruelle D. 1993.** *Azar y caos [Hasard et chaos]*. Madrid: Alianza Ed.
- Russell W. 1974.** *The Universal One*. University of Science & Philosophy.
- Schrödinger E. 1983.** *¿Qué es la vida? [What Is Life?]*. Barcelona: Tusquets Ed.
- Sheldrake R. 1989.** *Una nueva ciencia de la vida [A New Science of Life]*. Barcelona: Ed. Kairós.
- Smith C. 2008.** *Accelerating Evolution*. URL: <http://www.acceleratingevolution.info/>.
- Smuts J. 1927.** *Holism and Evolution*. New York: Macmillan.
- Snooks G. D. 1996.** *The Dynamic Society*. London: Routledge.
- Szent-Gyorgyi A. 1977.** Drive in Living Matter to Perfect Itself. *Synthesis* 1(1): 14–26.
- Teilhard de Chardin P. 1959.** *El fenómeno humano [Le Phénomène humain]*. Madrid: Taurus Ed.
- Thom R. 1987.** *Estabilidad estructural y morfogénesis [Stabilité structurelle et morphogénèse]*. Barcelona: Gedisa Ed.
- ‘t Hooft G. 2001.** *The Holographic Principle. Basics and Highlights in Fundamental Physics*: 37: 72–100.
- Vannini A. 2005.** From Mechanical to Life Causation. *Syntropy Journal* 1. URL: <http://www.sintropia.it/journal/english/2005-eng-1-2.pdf>.
- Vannini A., and Di Corpo U. 2011.** Quantum Physics, Advanced Waves and Consciousness. *Journal of Cosmology*. URL: <http://journalofcosmology.com/Consciousness101.html>.
- Waddington C. et al. 1976.** *Hacia una biología teórica [Towards a Theoretical Biology]*. Madrid: Alianza Ed.
- Wade J. 1996.** *Changes of Mind*. Albany: State University of New York.
- Watts A. 1972.** *El libro del tabú [The Book: On the Taboo Against Knowing Who You Are]*. Barcelona: Ed. Kairós.
- Wheeler J. A., and Feynman R. P. 1945.** Interaction with the Absorber as the Mechanism of Radiation. *Review of Modern Physics* 17: 157–161.
- Wheeler J. A., and Feynman R. P. 1949.** Classical Electrodynamics in Terms of Direct Interparticle Action. *Reviews of Modern Physics* 21(July): 425–433.
- Wheeler J. 1990.** Information, Physics, Quantum: The Search for Links. *Complexity, Entropy, and the Physics of Information* / Ed. by W. H. Zurek, pp. 354–368. Redwood City, CA: Addison-Wesley.
- Wigner E. 1961.** The Probability of the Existence of a Self-Reproducing Unit. *The Logic of Personal Knowledge* / Ed. by E. Shils. London: Routledge and Kegan Paul.
- Wilber K. 1996–1977.** *Sexo, ecología, espiritualidad [Sex, Ecology, Spirituality]*. (2 vols). Madrid: Gaia Ed.
- Wilber K. 2007.** *Espiritualidad integral [Integral Spirituality]*. Barcelona: Ed. Kairós.
- Young A. 1976.** *The Reflexive Universe*. New York: Delacorte Press.

Addendum 1**Toroidal Evolution**

Everything written so far has basically focused on unraveling the overall pattern of the evolution of life in the Universe, in general, and the human being, in particular. As we have seen, the result of this integral research clashes head on with the predictions of the materialist paradigm of classical science. Surprisingly, however, ground-breaking lines of research have started to appear in recent years in different branches of science – physics, chemistry, biology, neurology, among others – that are clearly in tune with the worldview that emerges from our evolutionary research and can hence provide key data capable of explaining this unexpected universal pattern that we are revealing here.

To show this suggestive harmony between different cutting-edge research in distinct fields of science, we will begin this addendum by outlining the fundamental characteristics of the universal dynamics that emerge from our inquiry into the rhythm of evolution. To this end, let us start out from the flat images represented in Figs 3-A and 3-B. These, we recall, summarized the overall pattern of universal evolution and the individual development of the human being from pole A (original energy) to pole Ω (final consciousness).

On the vertical axis of these graphs, we represented the entire spectrum of energy-consciousness, from the base – with a maximum of energy and a minimum of consciousness – to the summit – with a minimum of energy and a maximum of consciousness – with all the range of possible intermediate equilibria between these two fundamental facets of manifested reality, traditionally known as ‘the great chain of Being’ and which can be summarized as the ‘matter-life-mind-soul-spirit’ series. The horizontal axis of these graphs simply reflected the overall temporal scale, both of the universe and of the human being, from the origin (A) to the end (Ω).

Let us recall at this point a couple of ideas that we have discussed previously. We stated that all manifested reality inexorably appears in the form of dualities – there can be no object without subject, no energy without consciousness – and that, as all opposites are mutually dependent, these can be understood as polar manifestations of a reality that transcends them and is ‘prior’ to this dualization. We then argued that the original quantum vacuum posed by physicists and the final mystical void experienced by contemplatives are the same and unique Void, perceived by physicists objectively and by contemplatives in a subjective way, but which, in itself, is neither objective nor subjective, but rather ‘prior’ to this dual perspective. We finally explained that this Void does not allude to a distant metaphysical reality, but to the simple and pure Self-evidence of each present moment, which encompasses in itself all the manifestations of energy and consciousness that are observed in the spatiotemporal universe.

The other idea that we wish to recall here refers to our statement that, as there is no separation between subject and object in the aforementioned Self-evidence and therefore it is not ‘something’ that can be seen by ‘someone’, in

order to manifest itself relatively, it needs to polarize in appearance as subject and object, just as 0 can dualize in +1 and -1 without changing – other than formally – its absolute value. We thus proposed that, in its attempt to see itself, this Self-evidence apparently dualizes as an original pole (basically of energy) and a final pole (basically of consciousness), thus generating an illusory distance between the two, which, on vibrating – like the guitar string of our hypothesis – gives rise to a whole range of harmonics, which are precisely the levels of stability that the cycles of evolution that we have studied run through. We insist, however, that the presumed temporal distance between both poles is completely illusory, as in fact everything happens in the timeless Now of the ever present Self-evidence.

If we wish to graphically reflect these two ideas in the aforementioned Figs 3-A and 3-B which, as we have seen, summarize the overall patterns of universal evolution and the individual development of the human being from the A pole of original energy to the Ω pole of final consciousness – we need to perform a couple of manoeuvres on the flat surface on which we have represented both graphs (see Fig. 7-A).

First, having proposed that energy and consciousness are not two different realities, but rather the objective and subjective aspects of the same and ever present Self-evidence, we should unify the horizontal lines at the bottom and the top of the graph. As we have stated, these respectively represent the levels of maximum energy and maximum consciousness that are one and the same in fundamental reality. To do so, it will suffice to fold the flat surface of the drawing in on itself, aligning the upper line with the lower one, thus obtaining a cylinder (see Fig. 7-B).

Then, having affirmed that the temporal distance between the original moment (A) and the final moment (Ω) is illusory – as everything happens in the timeless Now – we should also unify the vertical lines on the left and the right of the graph. As already stated, these respectively represent the original and final moments of all evolutionary and developmental processes. To do so, once again we will fold our cylinder over onto itself, until the extreme vertical lines coincide, thus obtaining a figure similar to a ‘doughnut’ in which the central hole is reduced to a point without dimensions. It is what is called in geometry a ‘horn torus’ (see Fig. 7-C).

Bearing in mind what we have just explained – taking the guidelines that have been revealed in our research to their ultimate consequences – everything points towards a fascinating toroidal dynamic of energy-consciousness, both instantaneous and eternal, as the key element for integral comprehension of the Universe. According to this scheme, the flows start out from a Center without dimensions – in its facet A – follow a spiral path, divergent vortex, reach the external surface of the torus, and return to the same Center – in its facet Ω – via another spiral, convergent vortex, to subsequently restart its endless process from there. Next, we will try to outline the fundamental aspects of this dynamic that is beginning to be glimpsed, as we are possibly on the verge of solving

many of the enigmas and blind alleys in which official science and its obsolete materialistic paradigm are trapped.

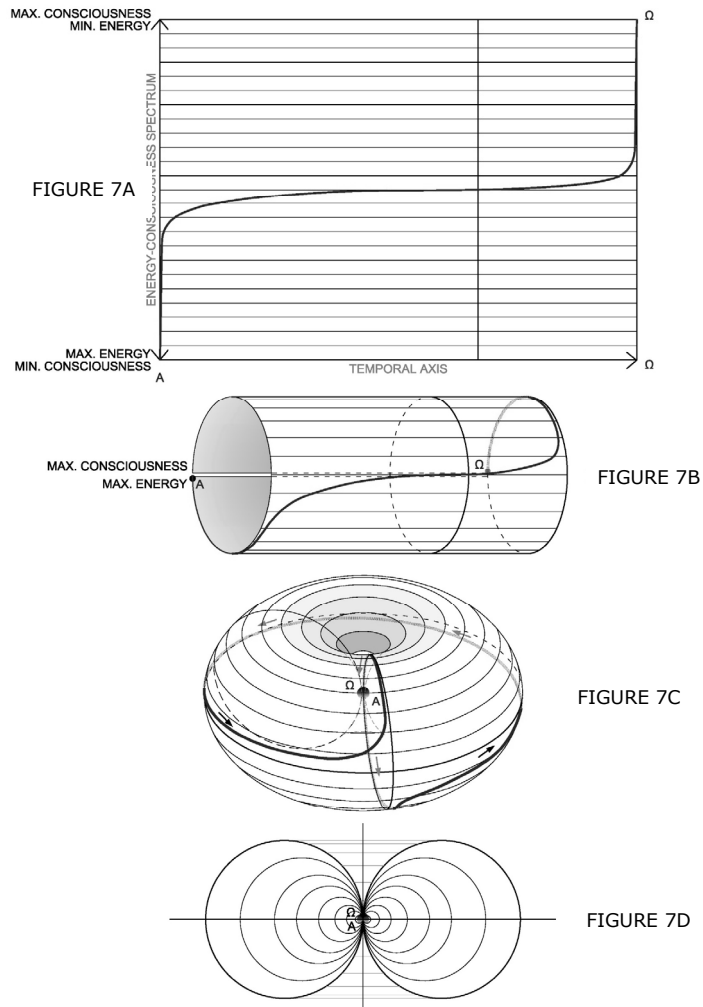

Fig. 7. Evolution of the energy-consciousness modelled by toroidal geometry. Flat representation of energy-consciousness process from pole A – maximum energy – to pole Ω – maximum consciousness (Fig. 7-A). Cylindric representation of Fig. 7-A (Fig. 7-B). The joining of the two ends of Fig. 7-B into a horn torus (Fig. 7-C). Scheme of nested toroidal fractal geometry (Fig. 7-D)

This fractal, toroidal structure of reality greatly facilitates the understanding of the evolutionary process. Thus, starting out from the idea that, in the final analysis, the sole protagonist of all the processes is the same and unique Self-evidence, we will now describe how the dynamics of evolution unfolds, step by step.

As we stated earlier, the non-manifest Void apparently polarizes as subject and object to perceive itself subjectively-objectively in infinite ways. Via this artifice, Self-evidence can delve into the furthest corners of its own infinity – illusively and fleetingly identifying its absolute Here-Now with any relative point-instant of pixelated space-time and, from there, contemplate itself from a certain perspective – at any level of the energy-consciousness spectrum of the nested torus returning instantaneously to its original fullness. Given that, as we have stated, the temporal dimension is purely imaginary, everything in fact occurs from instant to instant. This exit and return, moment-by-moment, between the non-dual foundation and its finite and fleeting manifestation in space-time allows us to update in the relative world of forms the potential levels of stability of the energy-consciousness spectrum, *i.e.* the entire hierarchy of ‘harmonics’ generated at the same original moment.

This recursive dynamic between the infinite Void and all its spatiotemporal forms is intrinsically creative and is facilitated by the unified field of memory that is gestating, step by step, at a fundamental level. All the information gathered at any point-instant of the manifested world is immediately introjected into this basic field of collective memory, whose potential is logically increased moment by moment. Thus, any entity, whatever the level of the spectrum in which it develops, has deep down in itself free access to the entirety of this unified field of memory, although it only connects with certain aspects of this field depending on its characteristics specific. The toroidal dynamic thus possesses a holographic structure, in the sense that each ‘part’ of itself has information of the ‘totality’, and is, in fact, a particular reflection of that totality.

From the perspective that we are proposing here, the evolutionary process can be understood as a natural expression of a toroidal, integral, non-dual, fractal and holographic dynamic of fundamental energy-consciousness. Via this recursive dynamic, the ever present Self-evidence is focused, moment after moment, on the successive levels of the ‘harmonic’ spectrum, beginning with the most basic ones – primarily energy – and ending at the highest levels – primarily consciousness. On each plane, it updates the specific potential of that level, integrating it with the aspects that have already emerged in previous levels. In each turn, starting from the resources available in the unified field of memory, it is projected in each concrete situation of space-time, it perceives that determined situation according to the possibilities of its structure, and, immediately,

introjects that information into the field of collective memory of the fundament. When a specific entity has unfolded the full potential of the stratum in which it basically develops and has integrated it with everything that has emerged in the preceding stages, once it has reached a specific level of complexity, it can resonate with the next 'harmonic' of the energy-consciousness spectrum, and thus ascend to a new rung of the long ladder of evolution, *etc.*

This toroidal, non-dual, fractal, holographic dynamic of the fundamental energy-consciousness that we are proposing has clear affinities with ancient intuitions of the wisdom traditions – the yin-yang of Taoism, the Celtic triskelion, the Egyptian seed of life, the Greek caduceus, the Hindu kundalini... even the symbol of ∞ is no other than the cross section of a horn torus! However, as we have stated, it is practically unacceptable for the materialist paradigm of classical science. In the wake of the emergence of quantum physics and relativistic theory, the landscape has changed drastically, with numerous innovative proposals emerging throughout the past century that, in these first decades of the new millennium, have begun to crystallize into a ground-breaking unified theory of fields that, in many aspects, is in tune with the toroidal evolution we are proposing here. Below, we provide a brief recap of some of the work, carried out in very different fields, that has shone new light on the landscape of science.

First, it is important to recall the pioneering proposals on toroidal dynamics, for example *The Universal One* by Walter Russell (1974), *Synergetics: Explorations in the Geometry of Thinking* by R. Buckminster Fuller (1981, 1982), *The Reflexive Universe* by Arthur M. Young (1976) and *A Brief Tour of Higher Consciousness: A Cosmic Book on the Mechanics of Creation* by Itzhak Bentov (2000). Concerning the creative trend of universal dynamics, one should mention Jan C. Smuts' 'holism' (Smuts 1927), Pierre Teilhard de Chardin's (1959) 'Omega Point' (*Le Phénomène Humain*), the notion of 'syntropy' proposed by Luigi Fantappiè (1942) and John A. Wheeler's 'participatory anthropic principle' (Wheeler 1990). As to the nested character of the world, reference should be made to the concept of 'holon' put forward by Arthur Koestler (1982) that of 'fractal geometry' proposed by Benoît Mandelbrot (1997) or Ken Wilber's 'holoarchival evolution' (1996). With respect to the holographic principle, it is essential to recall David J. Bohm (1988) and his theory of the 'holomovement' between deep reality or 'implicate order' and superficial reality or 'explicate order', the 'holographic brain' proposed by Karl H. Pribram (1971), Rupert Sheldrake's 'morphogenetic fields' (1989), the 'Akashic field' of information proposed by Ervin Laszlo (2013), and the work of Gerard't Hooft (2001), improved by Leonard Susskind. Regarding the relationship between the micro and macro scales, it is worth recalling the works in quantum neuro-bio-

physics by Stuart R. Hameroff and Roger Penrose (2014), and by Dirk K. F. Meijer and Hans J. H. Geesink (2017). We will finish this list of research on the cutting edge of science that resonate with some key points of our proposal, with particular reference to the ground-breaking work by Nassim Hamein and his collaborators William D. Brown and Amira Val Baker (2016),¹ as their *Holofractographic Theory of the Unified Field* brilliantly integrates the fractal, holographic and toroidal approaches that define our hypothesis.

(There are currently numerous websites on the Internet that echo this emerging perspective of a toroidal, holographic and fractal universe. The readers interested in this topic are recommended to consult the following websites: ‘The Fractal-Holographic Universe’ by Andreas Bjerve,² ‘Cosmometry’ by Marshall Lefferts³ and ‘Volution Theory’ by Peter Merry⁴).

Addendum 2

Entropic-Syntropic Evolution

Following one of his surprising mathematical discoveries, Carl F. Gauss stated, ‘I have had my results for a long time: but I do not yet know how I am to arrive at them’ (Arber 1954: 47). In the present research we find ourselves in the situation similar to that of Gauss. Throughout these pages, we have shown that, far from being a mere product of chance and meaningless, evolution follows a very precise rhythm of unfolding and folding between an original pole, basically of energy, and a final pole, basically of consciousness. How is this possible? What mechanism causes things to happen this way? So far, we have mainly limited ourselves to recounting some facts and to revealing the surprising pattern that links them. In this addendum, we will try to provide the key to explaining this mysterious behaviour of the evolutionary universe. As we will soon see, the transactional interpretation of quantum mechanics will provide us with the final clue.

Let us first delve a little into history to grasp the profound implications of the matter at hand. In the 1850s, the physicist and mathematician Rudolf Clausius established the concept of a thermodynamic system and postulated the thesis that in any energy transformation process, a small amount of energy is gradually dissipated across the system boundary. Energy thus gradually and irreversibly passes from a state of high potential and availability to a state of low potential and unavailability. Clausius coined the term ‘entropy’ to refer to the physical magnitude that measures this amount of energy which is not reusable

¹ See URL: <https://holofractal.org/spacememory.pdf>.

² See URL: <http://holofractal.net/>.

³ See URL: <http://cosmometry.net/>.

⁴ See URL: www.volutiontheory.net.

to do work and which is inexorably lost in the environment. The universe as a whole – which is an isolated system – tends to progressively distribute energy uniformly, increase its degree of homogeneity and disorder, and maximize entropy, and is therefore condemned to thermal death when it finally reaches the state of thermodynamic equilibrium. In this respect, the physicist Arthur Eddington affirmed that ‘*entropy is the arrow of time*’ (see Eddington 1928), as it forces physical events to move in a certain temporal direction, the one that is familiar to us, *i.e.* from the past to the future.

At the same time as Clausius was developing the science of thermodynamics, Charles Darwin was expounding the theory of evolution. Controversy was served! While according to the second law of thermodynamics, the processes of energy transformation inevitably tend towards dissipation, uniformity, disorder and homogeneity, it turns out that, at the same time, the processes of biological evolution move in exactly the opposite direction, *i.e.* towards order, differentiation, complexity and organization. Could it be that evolution does not follow the principles of thermodynamics? The response from the currently dominant scientific paradigm is limited to clarifying that the second law is only applicable to closed and isolated systems, that complex systems are open – that is, they exchange matter and energy with their environments, and that, although they decrease the entropy in their interior – generating order among their components – they do so at the cost of increasing it around them. Note that this answer only indicates that *there is no contradiction* between the second law of thermodynamics and the appearance of complex systems, but it *does not explain* this appearance at all, nor does it explain their subsequent maintenance without degradation, and even less so, their progressive development towards higher levels of complexity and organization. Not to mention, of course, the harmonic rhythm in which this surprising display of creativity takes place, as we have seen in our research.

Given that classical thermodynamics has not been able to explain the creative dynamics of life, there have been numerous authors over the course of more than a century who have attempted to provide an answer, from very different perspectives, to the dilemma thus posed. Let us recall, for instance, the ‘*élan vital*’ of the French philosopher Henri Bergson (1973), the ‘*entelechy*’ of the German biologist Hans Driesch (1914), the ‘*synchronicity*’ of the Swiss psychiatrist Carl Jung (1990), the ‘*Omega point*’ of the French palaeontologist Pierre Teilhard de Chardin (1959), the ‘*negative entropy*’ of the Austrian physicist Erwin Schrödinger (1983), the ‘*negentropy*’ of the French physicist Léon Brillouin (1959), the ‘*general plan*’ of the Hungarian physicist-chemist Michael Polanyi (1967), the ‘*principle of syntropy*’ of the Hungarian physiologist Albert Szent-Györgyi (1977), the ‘*syntropy*’ of the American architect Richard Buck-

minster Fuller (1981, 1982), the ‘higher laws’ of the Hungarian physicist Eugene Wigner (1961), the ‘biotonic laws’ of the German physicist Walter Elsässer (1958), the ‘chreode’ of the British biologist Conrad Waddington (Waddington *et al.* 1976), the ‘stratified stability’ of the Polish mathematician Jacob Bronowski (1970), the ‘retrocausality’ of the physicist French Olivier Costa de Beauregard (1994), the ‘holomovement’ of the American physicist David Bohm (1988), the ‘dissipative structures’ of the Russian chemist Ilya Prigogine (Prigogine and Stengers 1990), the ‘attractor’ of the American mathematician Edward Lorenz (1963), the ‘theory of catastrophes’ of the French mathematician René Thom (1987), the ‘fractal geometry’ of the Polish mathematician Benoît Mandelbrot (1997), the ‘Akashic field’ of the Hungarian systems theorist Ervin Laszlo (1988), the ‘participatory anthropic principle’ of the American theoretical physicist John Archibald Wheeler (1990), the ‘morphogenetic fields’ of the British biochemist Rupert Sheldrake (1989), the ‘Feigenbaum numbers’ of the American mathematician Mitchell Feigenbaum (1976), the ‘self-organized criticality’ of the Danish physicist Per Bak (Per Bak *et al.* 1987), the ‘Eros’ of the American integral philosopher Ken Wilber (2007), *etc.* It would seem that there is really something more than entropy in this evolutionary universe.

Our research is clearly in tune with many of the proposals mentioned above, some of which are even very close to solving the issue raised at the beginning of this addendum. Let us recap the question: What mechanism in nature is capable of causing evolution, in counterbalance to the second principle of thermodynamics, to follow a very precise divergent-convergent spiral pattern between an original pole of energy and a final pole of consciousness? As we have stated, the transactional interpretation of quantum mechanics may provide us with the long-awaited answer. Let us now consider some approaches that point in this direction.

In 1940, the Italian mathematician Luigi Fantappiè (1901–1956) sought to find a unified theory of the physical and biological world that would explain the emergence of complex and organized forms in a universe dominated by entropy (see Fantappiè 1942, 1993). He thought that the solution to this enigma had to be found in the fundamental principles of physics, in the very structure of the equations that combine quantum mechanics and special relativity. A key equation in this field is the d'Alembert operator, which, in the relativistic Klein-Gordon generalization of the Schrödinger wave equation, admits two types of solutions: *divergent waves*, described by the so-called ‘retarded potentials’, that branch from the original emitting source, and *convergent waves*, described by the ‘advanced potentials’, that converge at a future point that acts as an absorber or attractor. By analyzing the mathematical properties of these two solutions,

Fantappiè found that, while the positive solution moves forward in time and tends towards dissipation, disorder and homogeneity, the negative solution moves backward in time and tends towards concentration, order and complexity. He thus understood that the first solution actually follows the law of *entropy* – from the Greek *en* = divergent, and *tropos* = tendency – while the second obeys a symmetric law that he called *syntropy* – from the Greek *syn* = convergent, and *tropos* = tendency. Observing that the properties of the law of syntropy were exactly those characteristics of living beings, Fantappiè concluded that the increase in complexity in the evolutionary process is a consequence of the advanced – retrocausal – waves that emanate from attractors located in the future and go backwards in time. That is why, he stated, ‘*advanced waves are the essence of life itself*’. Life is caused by the future.

We insist that, far from being a mere product of speculation, these retro-causal waves appear in a rigorous mathematical way when the fundamental equations of special relativity and quantum mechanics are studied jointly. What is truly surprising is that the researchers who made their theoretical discoveries later refused to accept their real existence, not for scientific reasons, but simply because of the preconception that the final causes were impossible. However, Luigi Fantappiè refused to eliminate half of the solutions of the fundamental equations of the Universe and consistently argued that life is subject to a double causality: efficient causality and final causality. He thus proposed replacing the mechanistic and deterministic model of the Universe with a new, entropic-syntropic model, in which the expansive forces (entropy) and the cohesive forces (syntropy) worked together, so that the unfolding of phenomena was not only a function of the initial conditions, but also depended on a final attractor.

One of Fantappiè's main students, the physicist Giuseppe Arcidiacono (1927–1998), together with his twin brother Salvatore (1927–1998), a chemist by profession, re-examined the unitary theory of the physical and biological world of their mentor in order to clarify the separation established between entropic and syntropic phenomena (see Arcidiacono G. and Arcidiacono S. 1991; Arcidiacono 1992). They proposed a new version of the theory in which they argued that there are actually no ‘pure’ entropic or syntropic events, but that there exist both entropic and syntropic components acting together, in all phenomena, whether physical or biological. The result is an entropic-syntropic model of the universe with a ‘cybernetic structure’ that makes it possible to establish a link between Fantappiè's unitary theory and the most recent research on systems theory, chaos and complexity.

Without knowledge of Fantappiè's work, the Italian experimental psychologist Ulisse Di Corpo independently formulated the theory of syntropy in 1977 from a slightly different starting point (see Di Corpo and Vannini 2011,

2012). Instead of starting from the d'Alembert operator of the wave equation of quantum mechanics, as Fantappiè had done, he began by working with the original and complete energy-momentum-mass equation of Einstein's special relativity: $E^2 = p^2 c^2 + m^2 c^4$, where E is energy, p is momentum, m is mass, and c is the constant for the speed of light. As this is a second-degree equation, it always has two solutions: one positive and one negative. The positive solution describes energy that diverges forward in time from a past source, while the negative solution describes energy that diverges backward in time from a future source. At the time, this second solution was considered unacceptable because it implied retrocausality, *i.e.* the effect took place before its cause. Einstein managed to solve this problem by considering that momentum, p , is practically equal to zero, because the speed of physical bodies is extremely small compared to the speed of light. In this way, the complex Einstein equation of energy-momentum-mass was simplified into the now famous equation $E=mc^2$, which has only one positive solution.

However, in 1924, the Austrian theoretical physicist Wolfgang Pauli discovered the spin of electrons. Spin is an angular momentum, a rotation of the electron on itself at a speed close to the speed of light. Thus, in this case, momentum, p , cannot be considered equal to zero and therefore the energy-momentum-mass formula must be used in its full version. For this reason, in 1928, when combining Einstein's special relativity with quantum mechanics, the British theoretical physicist Paul Dirac applied the complete energy-momentum-mass equation to the study of electrons and once again encountered the unwanted dual solution – positive and negative – in the form of electrons and their antiparticles. The Dirac equation thus leads to a Universe made of matter moving forward in time and antimatter moving backward in time. The antiparticle of the electron, predicted theoretically by Dirac, was observed experimentally in 1932 by the American physicist Carl Anderson – by photographing the traces of cosmic rays in a cloud chamber – and was given the name *positron*. Anderson thereby became the first person to empirically prove the existence of the negative energy solution and waves that propagate backward in time, from the future to the past. The negative solution was thus no longer an impossible mathematical absurdity, but became empirical evidence. We now know that each subatomic particle has a corresponding antiparticle that flows in the opposite direction of time, from the future to the past: antielectrons, antiprotons, antineutrons, *etc.*

The meeting between Ulisse Di Corpo and the cognitive psychologist Antonella Vannini, in 2001, relaunched research on the entropic-syntropic theory⁵

⁵ Some of the information contained in this addendum is taken from URL: <http://www.sintropia.it/journal/index.htm>.

(see Vannini 2005, 2011). At the time, Fantappiè was not able to devise a way to reveal the existence of future causes in the laboratory. In recent decades, however, a growing number of studies – by Dean Radin, Dick Bierman, James Spottiswoode, Patrizio Tressoldi, among others – have demonstrated the existence of prior reactions to stimuli in the parameters of skin conductance or cardiac frequency. For her part, in her doctoral work, Vannini managed to carry out four experiments using heart rate measurements to study Fantappiè's proposal regarding retrocausality and António Damasio's learning effect. The hypothesis on which she worked was very simple: if life is supported by syntropy, the parameters of the vital systems that support life, such as the autonomic nervous system, should show retrocausal activations. Her thesis provided ingenious methodologies and positive experimental results that succeeded in turning syntropy studies from a mere hypothesis into a sound scientific theory supported by rigorous mathematics and abundant experimental evidence.

Around 1940, the American theoretical physicists John A. Wheeler (1911–2008) and Richard Feynman (1918–1988) proposed what is known as ‘absorber theory’, which is an interpretation of electrodynamics that derives from the assumption that the solutions of the electromagnetic field equations must be invariant under time inversion symmetry (see Wheeler and Feynman 1945, 1949). It is hence a symmetric theory in time. In general, Maxwell's equations and the equations of electromagnetic waves have two possible solutions: a retarded solution moving forward in time and an advanced solution moving backward in time. In principle, there is no apparent reason for the breaking of time reversal symmetry, pointing to a preferential direction of time. Nonetheless, advanced solutions are normally ruled out in the interpretation of electromagnetic waves. In absorber theory, however, charged particles are considered both as emitters and absorbers, and the emission process is related to the absorption process in the following way: both the retarded waves that travel from the emitter to the absorber and the advanced waves that travel from the absorber to the emitter are taken into consideration; the sum of the two, however, results in causal waves, although retrocausal solutions are not ruled out a priori.

From the start, the traditional interpretation of quantum mechanics – the Copenhagen interpretation – has shown a fierce reluctance to accept negative solutions as actually existing, *i.e.* those that move backwards in time, which naturally follow on from the fundamental equations. Diverse research over the last century has shown, over and over again, the major difficulties of this standard interpretation in assuming certain empirically contrasted phenomena, such as non-locality, entanglement and retrocausality. This led the American physicist John G. Cramer to propose an alternative interpretation in 1986, which he called the Transactional Interpretation of Quantum Mechanics (TIQM) (see

Cramer 1986, 2016). Inspired by Wheeler and Feynman's 'absorber theory', the transactional interpretation describes quantum interactions in terms of a *standing wave formed by interference between retarded (forward in time) and advanced (backward in time) waves*. It is a 'pure' interpretation of quantum mechanics, in the sense that it does not add anything ad hoc, but simply provides a physical referent for a part of the mathematical formalism used in standard textbooks – advanced waves – that the traditional interpretation has repeatedly eliminated. Its predictions are therefore the same as those of the Copenhagen interpretation, but nevertheless it avoids many of its problems and solves, in a simple and elegant way, all the great quantum mysteries, such as the EPR paradox, Schrödinger's cat, Wigner's friend, Wheeler's retarded solution, *etc.* This model thus provides a clear visual picture that explains, without any artifice, the puzzling experimental results that appear daily in quantum physics laboratories around the world. According to the astrophysicist and science writer John Gribbin, Cramer's interpretation of quantum mechanics 'provides the best complete picture of how the world works at the quantum level', and, 'hopefully, it will replace the Copenhagen interpretation as the standard way of thinking about quantum physics for the next generation of scientists' (see Gribbin 1996).

This transactional model may be summarized as follows. The emitter produces a retarded wave of 'offer', forward in time, which travels towards the absorber, causing the absorber to produce an advanced wave of 'confirmation', backward in time, which travels back to the emitter. The interaction is repeated cyclically until the net exchange of energy, momentum, angular momentum and other conserved quantities satisfies the quantum boundary conditions of the system, at which point the transaction is definitively completed and the real quantum event, the 'collapse of the wave function', occurs. Of course, the 'pseudo-temporal' sequence in this account is only a semantic convenience to describe a process that is actually timeless, given that, according to the laws of relativity, time does not pass at all from the point of view of waves, because, as they travel at the speed of light, their moment of departure and their moment of arrival are one and the same moment. An observer unaware of these internal mechanisms of nature would perceive only the completed transaction, which could be reinterpreted as the passage of a single retarded photon, *i.e.* positive energy, traveling at the speed of light from an emitter to an absorber. In a more simplified version, we could say that the emitter produces an 'offer' wave that travels to the absorber, that the absorber then returns a 'confirmation' wave to the emitter, and that the transaction is finally completed with a 'handshake' – a standing wave – through space-time, via which a bidirectional contract is sealed between past and future. As Cramer states,

This universe (...) advances in time at the quantum level through a chain of handshakes between the past and the future (...) The future goes back to make an accommodation with the past that allows a quantum event to happen, to become reality. Each quantum event emerges into reality as a result of a feedback loop between the past and the future. These are allowed time-shaped loops that give rise to the universe (see Cramer 1986).

Extending the work of John Cramer, the American physicist and philosopher of science Ruth E. Kastner has developed a new Transactional Interpretation, called Relativist Transactional Interpretation (RTI) or Possibilist Transactional Interpretation (PTI), which holds that quantum wave functions do not move in the physical universe, but exist as ‘possibilities’ in Hilbert’s multidimensional space, from which transactions emerge in the ‘real’ universe (see Kastner 2012, 2015, 2019). Kastner proposes considering the outgoing offer waves and many incoming confirmation waves as ‘possible’ transactions, existing outside of space-time, of which only one becomes empirically ‘real’. She suggests defining them as ‘potentia’ which Aristotle called the ability to be something in the future, in tune with the statement by the German theoretical physicist Werner Heisenberg, ‘Elementary atoms or particles are not real in themselves; they form a world of potentialities or possibilities, and not so much a world of things or of facts or data’. In this sense, Kastner states that offer and confirmation waves are sub-empirical and pre-space-time ‘possibilities’, *i.e.* they have not yet appeared in space-time, and therefore calls them ‘incipient transactions’.

Kastner calls for a new metaphysical category to describe those ‘not quite real possibilities’ which, far from being mere abstractions, constitute a higher-dimensional world whose structure is described by the mathematics of quantum theory. She raises the need to consider such ‘possibilities’ as a part of a reality that encompasses much more than what is contained in space-time. In fact, space-time events, the events of the concrete world that we experience around us with our five senses, are products that emerge from the transaction processes – timeless and non-local – that take place in the quantum realm. The ‘iceberg’ metaphor used by Freud to describe the human subconscious can equally be applied to Kastner’s ‘ontological realm of possibility’ or ‘quantumland’. ‘Quantumland’ refers to the mass of the iceberg that exists beyond our sight, while the tip, the space-time appearance, is only a small part of everything that is the physical universe. Although they take place outside of space-time, quantum processes constitute a fundamental part of that universe.

At the beginning of this addendum, we have wondered how it was possible for evolution to follow such a precise unfolding and folding rhythm between the original and final poles, as has been shown throughout this research. And

we asked the question: Is there some natural mechanism capable of causing things to happen in such an unexpected way? We thus suggest that we may find the long-awaited answer in the so-called Transactional Interpretation of Quantum Mechanics. For this reason, in the previous paragraphs we have summarized the basic points of Luigi Fantappiè's entropic-syntropic theory, on the one hand, and of John Cramer's transactional interpretation, on the other. Next, we will recall some fundamental ideas of our 'non-dual evolution' to consider how Fantappiè's and Cramer's proposals provide us with the definitive key to explaining the mysterious evolutionary pattern.

As we have previously seen, all manifested reality inexorably appears in the form of dualities – there is no object without a subject, no energy without consciousness, or outside without inside – and, as all opposites are mutually dependent, we can understand them as polar manifestations of a reality that transcends them and that is 'prior' to this dualization. We hence proposed that the original quantum void posed by physicists and the final mystical void experienced by contemplatives are no other than one and the same Void, perceived by physicists objectively and by contemplatives subjectively, but which, in itself, is neither objective nor subjective, but 'prior' to this dual perspective. Finally, we clarified that this Emptiness does not refer to a distant metaphysical reality, but to the simple and pure Self-evidence of each present instant, which encompasses in itself all the manifestations of energy and consciousness that are observed in the space-time universe. According to this perspective, ultimate reality is hence not solely energy, as the materialists claim, nor solely consciousness, as the spiritualists claim, but the ineffable non-duality of these two apparent facets. The Universe, dear reader, is made up of the simple and evident Presence that you are in this precise timeless moment that is Now and always Now.

We have also stated that, as there is no separation between subject and object in this absolute Self-evidence, and therefore it is not 'something' that can be seen by 'someone', in order to manifest itself relatively before itself, it needs to be polarized in appearance as subject and object, in the same way that 0 can dualize into +1 and -1 without changing its intrinsic value. For this reason, we proposed that, in its attempt to see itself, Self-evidence apparently dualizes as an original pole (basically of energy) and a final pole (basically of consciousness), thus generating, in the same primordial moment, an illusory distance between the two, which, on vibrating like the guitar string in our hypothesis gives rise to a whole range of harmonics, which are precisely the 'potential levels of stratified stability' (see Bronowski 1970) that will be successively updated through the cycles of the evolution that we have studied, covering the entire spectrum of reality from the most basic strata – of enormous energy and little consciousness – to the highest of little energy and enormous consciousness.

It is also important to understand that everything happens in the absolute Now and that time is simply an imaginary construction with which our minds order the emergence of successive relative instants. For this reason, when we use the terms ‘past’ or ‘future’, we are not talking about distant situations, but are only referring to partial aspects of the immutable timeless Now that contains the totality of ‘time’. We stated a moment ago that the unmanifested Emptiness is apparently polarized as subject and object so as to perceive itself subject-objectively in infinite ways. Via this ploy, Self-evidence can delve into the furthest corners of its own infinity fleetingly identifying its absolute Here-Now with any relative point-instant of pixelated space-time, in order to contemplate itself from a certain perspective at any level of the spectrum of energy-consciousness, immediately returning to its original fullness. The time dimension is thus purely imaginary. Everything actually happens from moment to moment. This departure and return instant after instant between the non-dual foundation and its finite and fleeting manifestation in space-time allows the *potential* levels of stability of the energy-consciousness spectrum to be *actualized* in the relative world of forms, *i.e.* the entire hierarchy of standing waves – musical harmonics – generated at the same original instant. For an integral understanding of the universe, we will thus have to refer to three different, although dynamically interrelated, facets: *non-dual absolute reality* – the simple and timeless Self-evidence without form, *potential relative reality* – the potential spectrum of energy-consciousness generated in the original polarization and *space-time relative reality* – the actualization moment after moment of the successive potential levels of stratified stability.

In Fig. 8 we have once again represented the complete pattern of the unfolding-folding process between the original pole of energy A and the final pole of consciousness Ω , as it manifests itself in global evolution and in the individual development of the human being. Let us recall that this trajectory can locate its ‘fundamental sound’ at any level of the energy-consciousness spectrum, as we stated previously in Fig. 3. Precisely, in this graph we saw that the inflection point P of the trajectory takes place on the border between the ‘material’ and the ‘vital’ levels in the case of human *phylogeny*, and between the ‘mental’ and the ‘soul’ levels in the case of our *ontogeny*. As we have stated in the previous paragraph, given that each point-instant of the relative world is born and returns, moment after moment, from and towards its timeless foundation, we can also affirm that this complete unfolding-folding trajectory similarly reflects the whole life of each moment – what Ken Wilber calls *microgeny* – which can be focused on any level of the energy-consciousness spectrum, from the most physical to the most spiritual planes.

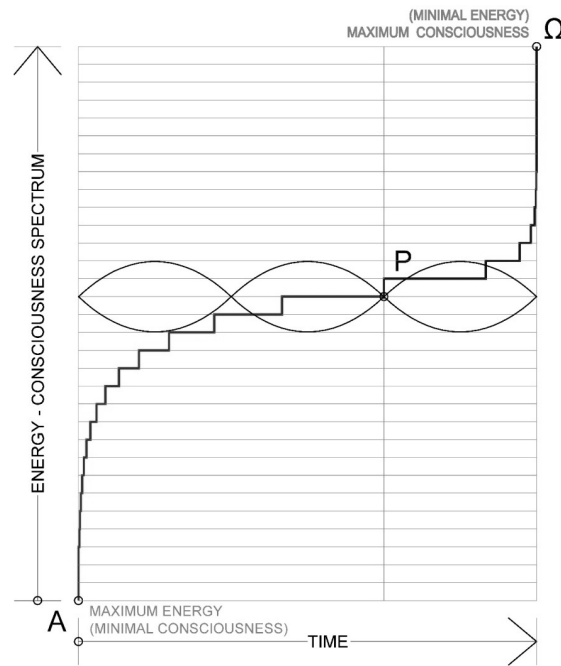

LUIGI FANTAPPIÈ ENTROPY - SYNTROPY THEORY	ORIGIN → CAUSALITY DIVERGENCE → EFFECT ENTROPY → RETROCAUSALITY CONVERGENCE → FINAL SYNTROPY → ATTRACTOR
JOHN G. CRAMER TRANSACTIONAL INTERPRETATION	EMITTER (PAST) → RETARDED WAVE "OFFER" → TRANSACTION "HANDSHAKE" → ADVANCED WAVE "CONFIRMATION" → ABSORBER (FUTURE)

Fig. 8. Each level of stability (standing wave) in the evolutionary process of energy-consciousness arises from the simultaneous and coordinated action of the flows from the original emitting pole (forward in time) and from the final absorbing pole (backward in time), in line with the proposals by Fantappiè and Cramer

At the bottom of Fig. 8, we highlight the resonance between our evolutionary scheme – the unfolding-folding fractal pattern between pole A and pole Ω – and the proposals of Fantappiè – regarding the entropic-syntropic (divergent-convergent) dynamics between the original source and the final attractor – and Cramer – regarding the *handshakes* of retarded *offer* waves and advanced *confirmation* waves between emitters and absorbers. Herein lies the answer to the question we posed at the beginning of this addendum as to what natural mechanism can cause the evolutionary pattern to unfold in such an unexpected way. The entropic-syntropic theory and the transactional interpretation make it clear to us that *all the events of the space-time universe arise, moment after moment, via the simultaneous and coordinated action of flows from the actualized 'past' and the potential 'future', and, ultimately, from the original emitter and final absorber.* In this sense, we could complement Einstein's phrase '*God does not play dice with the universe*' (see Einstein 1926), stating that he does, but that he only counts the winning moves. That is, of all the potential offer waves from the past, only those that are in resonance with the confirmation waves from the future are updated in space-time. This, in turn, brings to mind Teilhard de Chardin's idea about '*the preferential utilization of chance*'.

This approach greatly clarifies the so-called 'anthropic principle', which suggests that we live in a carefully adjusted universe, *i.e.* in a universe that seems to have been meticulously arranged to allow the existence of life and mind, because, if any of the basic physical constants had been different, the appearance of life as we know it would not have been possible. If, as we see here, all the events of the universe arise from the interaction and consensus between the past and the future, it is completely natural that, without having to resort to any external designer, the first events of the universal process were already fully coordinated and adjusted to future events. How could it be otherwise! In the same way, with respect to our divergent-convergent pattern, we must state that all the successive levels of the evolutionary ladder – which, as we saw in our research, unfold at the rate set by the second harmonic – are defined, like all quantum interactions, by *standing waves formed by interference between retarded (forward in time) and advanced (backward in time) waves*, which is precisely the core of Cramer and Kastner's transactional interpretation!

From the perspective of the mechanistic paradigm, our proposal regarding a fractal pattern of unfolding-folding between the original and final poles in the evolutionary process is complete nonsense. However, as we have just seen, from the syntropic and transactional perspective, this pattern is precisely the most natural, coherent expression with respect to the intrinsic simultaneously causal and retrocausal mechanism of the universe. Materialism has tried to understand the world by dispensing with half of it and has failed in an attempt to explain life, mind or consciousness. It has sufficed to take reality in its entirety in order to shine light on all areas of the panorama. Is not it time to change the paradigm?